

MS+H

DE   Installationsanleitung	DK   Installationsvejledning
GB   Installation Instructions	SE   Installationsanvisning
FR   Notice d'installation	CZ   Návod pro instalaci
IT   Manuale di installazione	PL   Instrukcja instalacji
ES   Manual de instalación	LT   montavimo instrukcijos
NL   Installatiehandleiding	HU   Telepítési útmutatók

- DE | Lesen Sie diese Installationsanleitung vor Montagebeginn!  
Montage nur durch sachkundige, qualifizierte Personen!
- GB | Read these instructions before installation!  
Installation should only be carried out by skilled, qualified personnel!
- FR | Prenez soin de lire le présent manuel d'installation avant le début du montage!  
Montage seulement par des personnes compétentes et qualifiées!
- IT | Leggere le presenti istruzioni di installazione prima di intraprendere i lavori di montaggio!  
Il montaggio è consentito esclusivamente a personale esperto e qualificato!
- ES | Lea estas instrucciones de instalación antes de comenzar el montaje!  
El montaje solo debe realizarlo personal experto y cualificado.
- NL | Lees deze installatiehandleiding alvorens met de montage te beginnen!  
De montage mag uitsluitend plaatsvinden door deskundige, gekwalificeerde personen!
- DK | Læs installationsvejledningen før montagen påbegyndes!  
Montagen må kun udføres af fagligt kvalificerede personer!
- SE | Läs den här installationsanvisningen innan monteringen påbörjas!  
Installationen bör endast utföras av utbildad, kvalificerad personal!
- CZ | Přečtěte si tento návod k instalaci před začátkem montáže!  
Montáž smí provádět jen odborné a kvalifikované osoby!
- PL | Przed rozpoczęciem montażu przeczytać niniejszą instrukcję!  
Montaż tylko przez wykwalifikowanych fachowców!
- LT | Prieš montuodami perskaitykite šią įrengimo instrukciją!  
Montuoti leidžiama tik profesionalams, kvalifikuotiems asmenims!
- HU | A szerelés megkezdése előtt olvassa el ezt a telepítési útmutatót!  
A szerelést csak megfelelő szakképesítéssel rendelkező jogosult személy végezheti!



## DE | Verwendung

Montagesystem für die Installation von gerahmten PV-Modulen von 30 bis 50 mm Dicke auf Schrägdächern mit folgenden Eigenschaften:

- Stahl- und Aluminiumtrapezblech
- Blechstärke Stahl ab 0,63 mm
- Blechstärke Aluminium ab 0,8 mm
- Breite Hochsicke min. 20 mm
- Dachneigung 3° - 70°

Eine Montage auf Sandwichdächern erfordert die Zustimmung des Herstellers.

Module sind immer quer zu montieren.

Berücksichtigen Sie bei der Montage die gültigen Regelwerke, den Stand der Technik und die aktuellen Arbeitsschutzrichtlinien, insbesondere bei Arbeiten auf dem Dach.

### Mitgeltende Dokumente

"Allgemeine Installations-, Wartungs- und Montagehinweise"

"Sicherheitshinweise zur Installationsanleitung"

"Garantiebedingungen und Haftungsausschluss."

Diese Dokumente sind verfügbar unter [www.renusal.com](http://www.renusal.com)

### Gewährleistung:

Die Gewährleistung gilt nur bei Verwendung des original MetaSole+ Komplettsystems.

Den aktuellsten Stand der Montageanleitung finden Sie unter: [www.renusal.com](http://www.renusal.com)



## GB | Use

The following guide schematically presents the setup of a specific 2x1 module configuration tested to MCS 012 Issue 3.0 with 6 fixations at a PV module surface of 5,4 m<sup>2</sup>. Permissible wind uplift values can be found in Annex A.

Mounting system for installing framed PV modules on pitched roofs with the following characteristics:

- Steel and aluminium trapezoidal metal sheet roof
- Steel sheet thickness from 0.63 mm
- Aluminium sheet thickness from 0.8 mm
- Min. width of raised beads 20 mm
- Roof pitch 3° - 70°
- The clamping area must be between 22 mm and 1/4 of the module length, measured from the edge of the module, as shown in Figure 1
- Max. PV module dimensions 2333 mm x 1134 mm
- Frame thickness between 30 - 50 mm

The manufacturer's consent should be obtained prior to installation on sandwich roofing.

Modules are always to be mounted in landscape.

Be sure to observe the relevant regulations, latest technology standards and current health and safety guidelines during installation and, in particular, while working on the roof.

### Applicable Documents

"General installation, maintenance and assembly instructions"

"Warranty and Disclaimer."

These documents are available at [www.renusal.com](http://www.renusal.com)

### Warranty:

The warranty only applies if an original MetaSole+ complete system is used. The current version of these installation instructions is available at: [www.renusal.com](http://www.renusal.com)

Tests/certificates:

- abZ Z-14.4-816
- For MCS012 certified products please see Annex A

**Figure 1**

The clamping area must be between 22 mm and 1/4 of the module length, measured from the edge of the module. Cut the rail so that it exceeds the end clamp by at least 35 mm or the module edge by 62 mm.

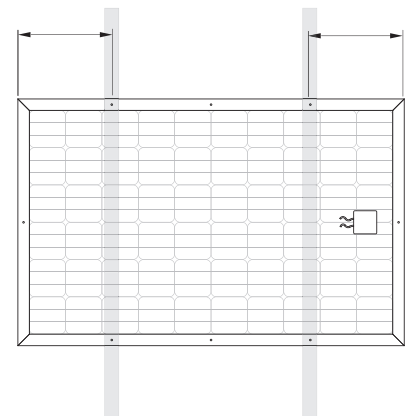

**Vor Montage muss die Standsicherheit des PV-Systems nachgewiesen werden. Die Gebäudekonstruktion muss die zusätzlichen Lasten sicher aufnehmen können.**



**The structural stability of the PV system must be verified before installation. The building must be able to support the additional weight safely.**



**La stabilité statique du système photovoltaïque doit être validée avant le montage. La construction du bâtiment doit pouvoir absorber sûrement les charges supplémentaires indues au montage.**

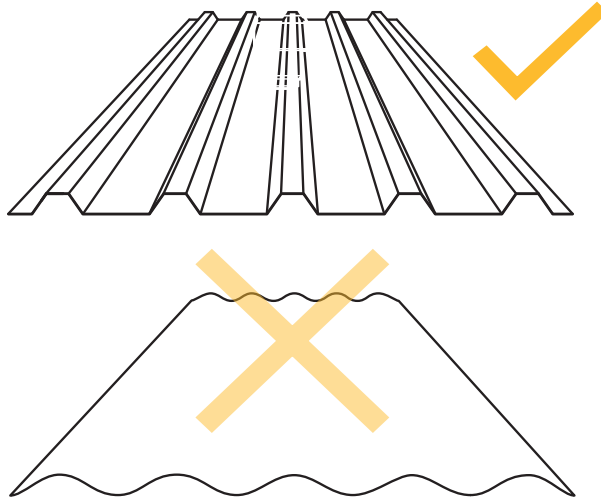

---

**A 420423**

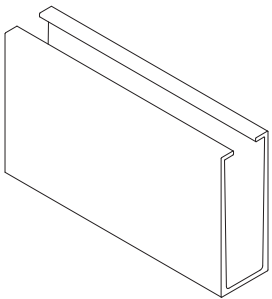

---

**A**

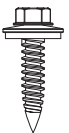

SW 8 6,0x25 E16

● ●8

FE (0,63-1,50 mm)

AL (0,80-2,00mm)

---

**+**

**A**



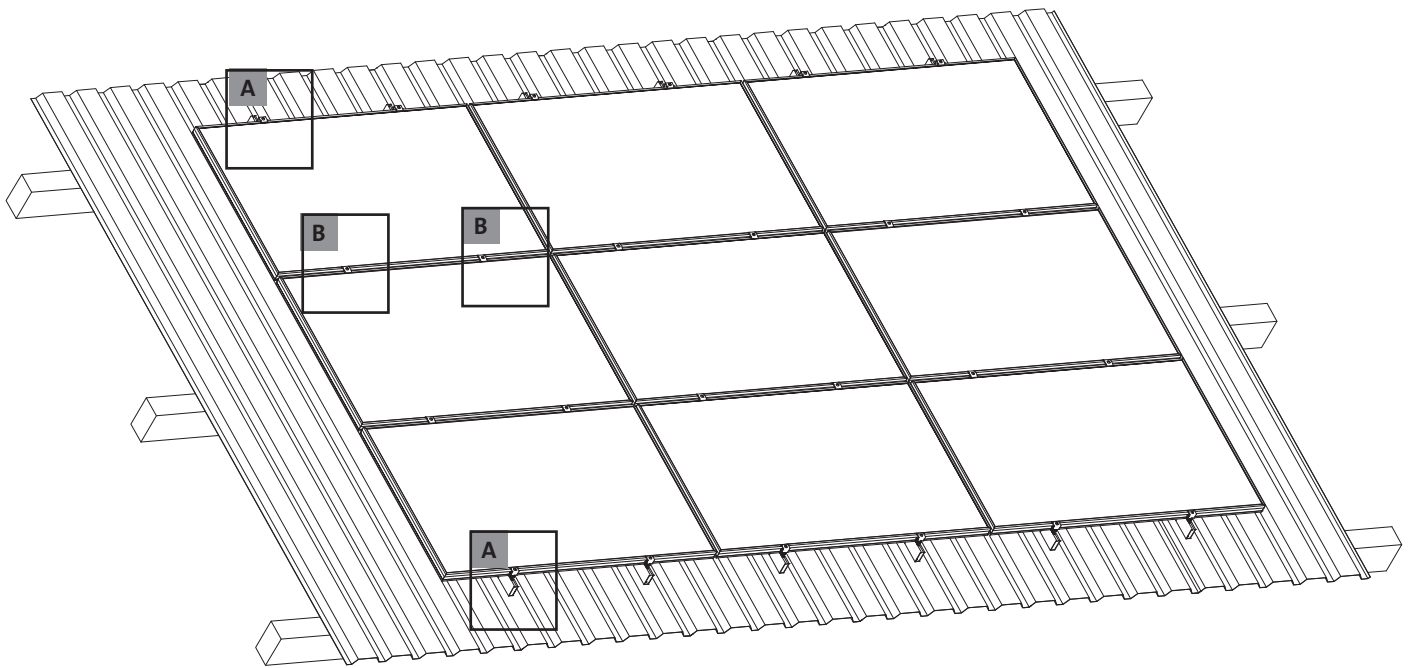

**A 420081**

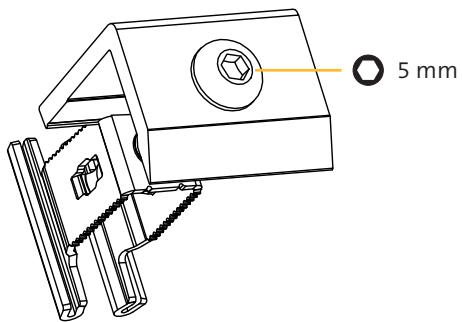

**B 420082**

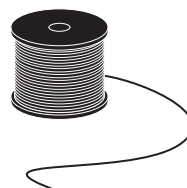
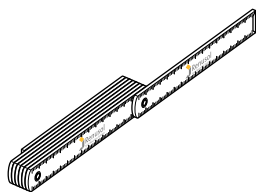
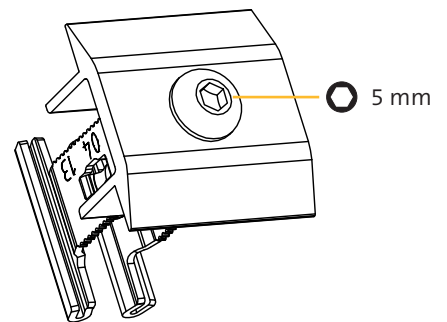

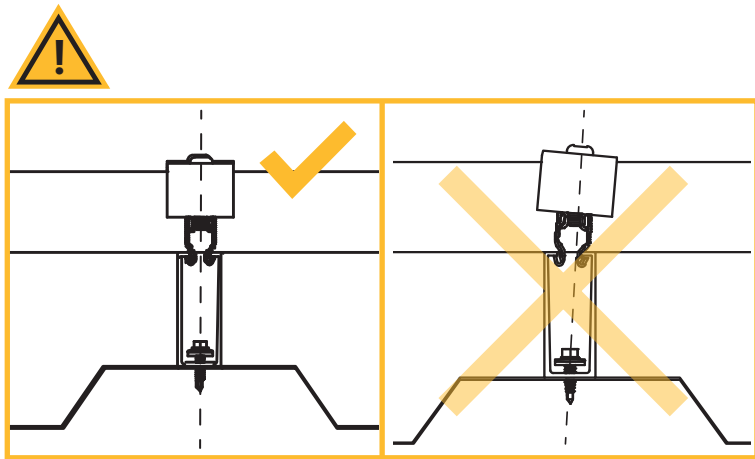
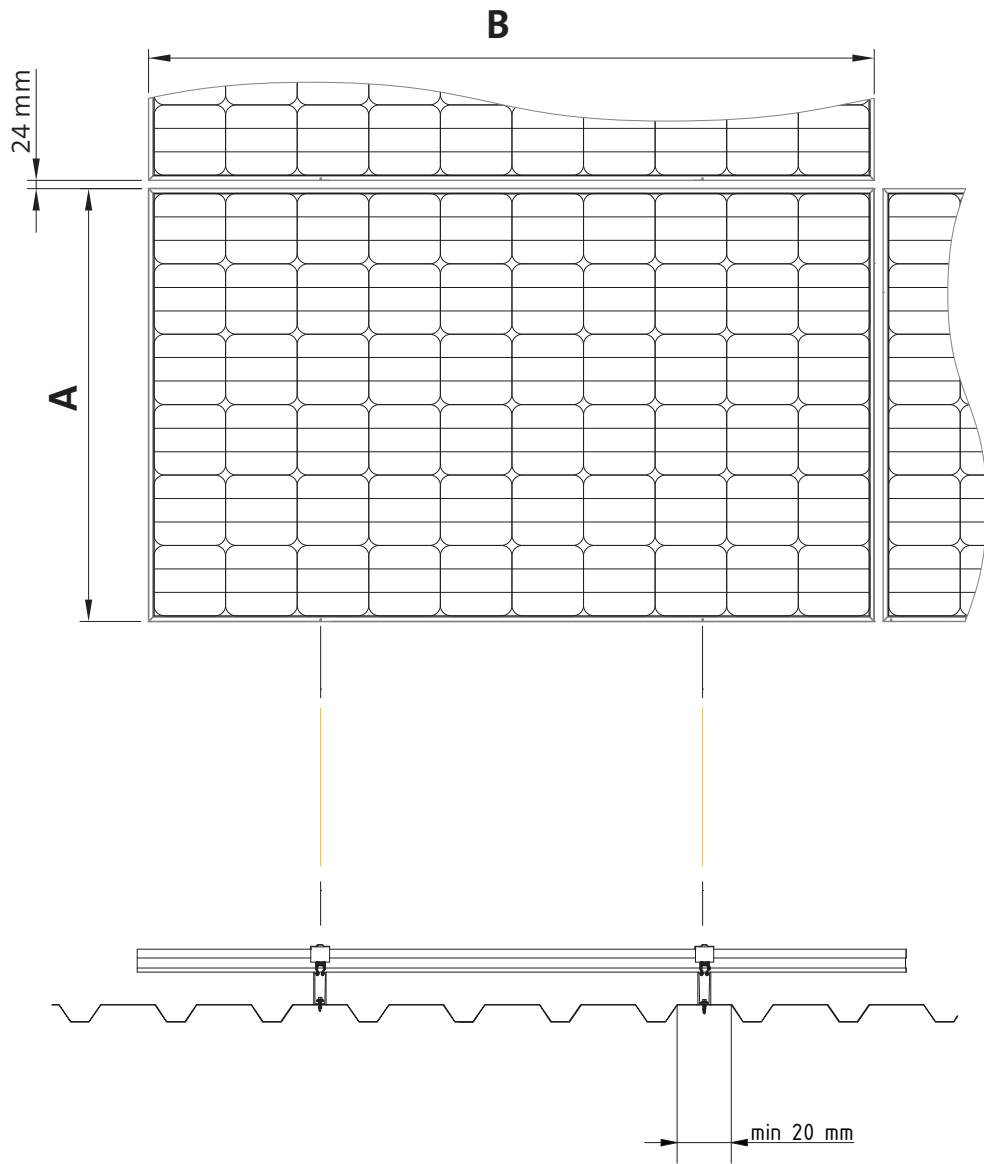

1.

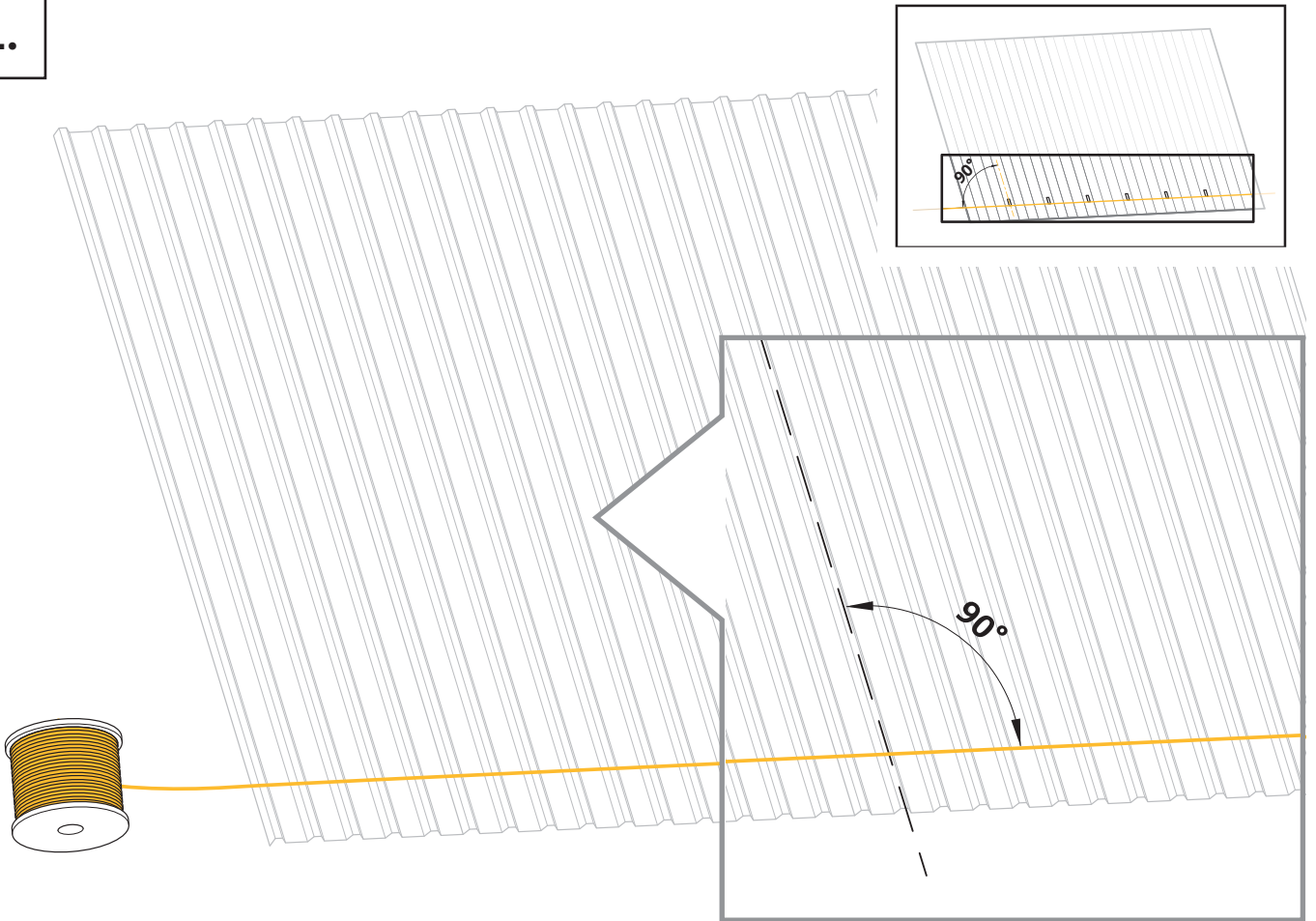

2.

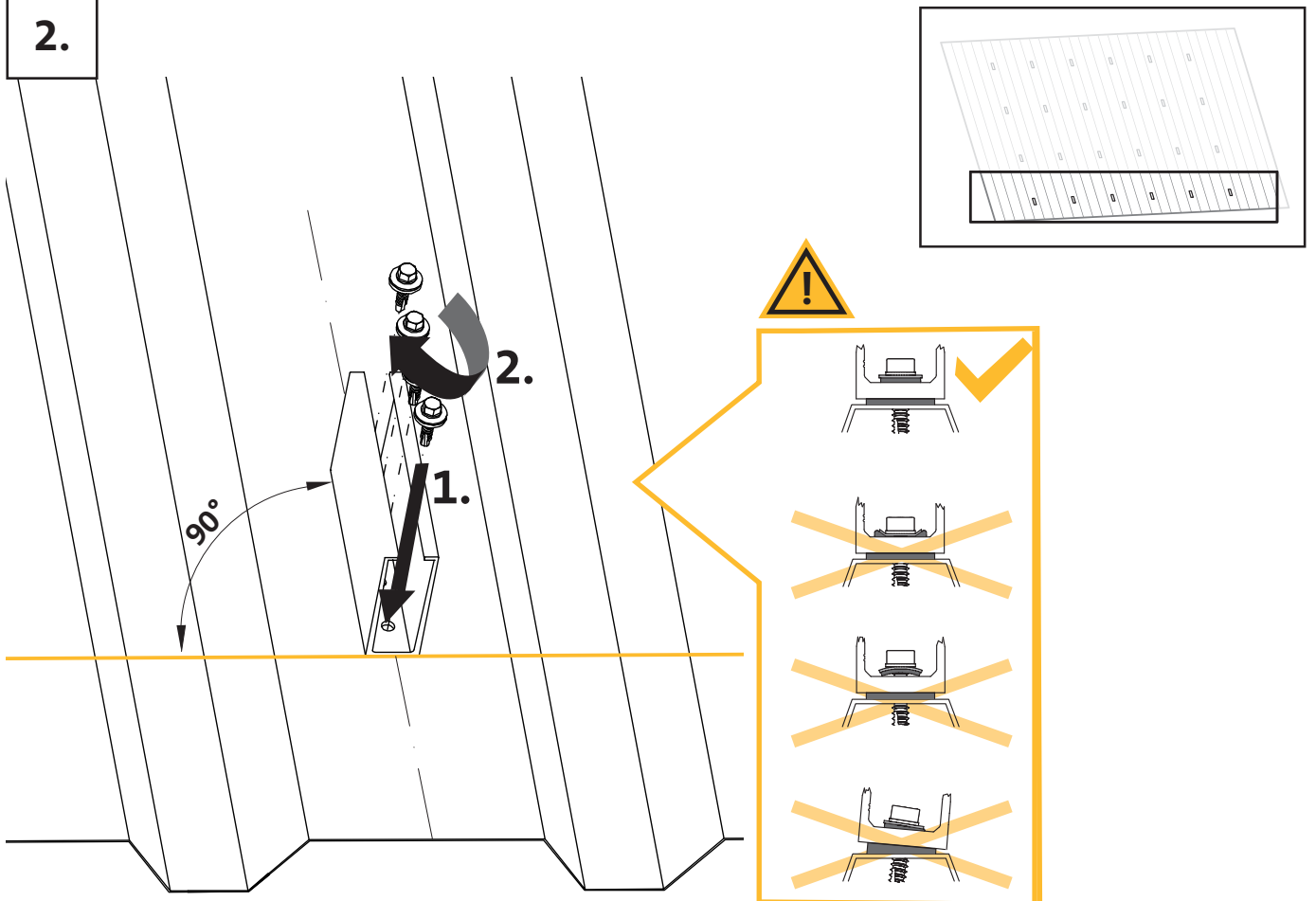

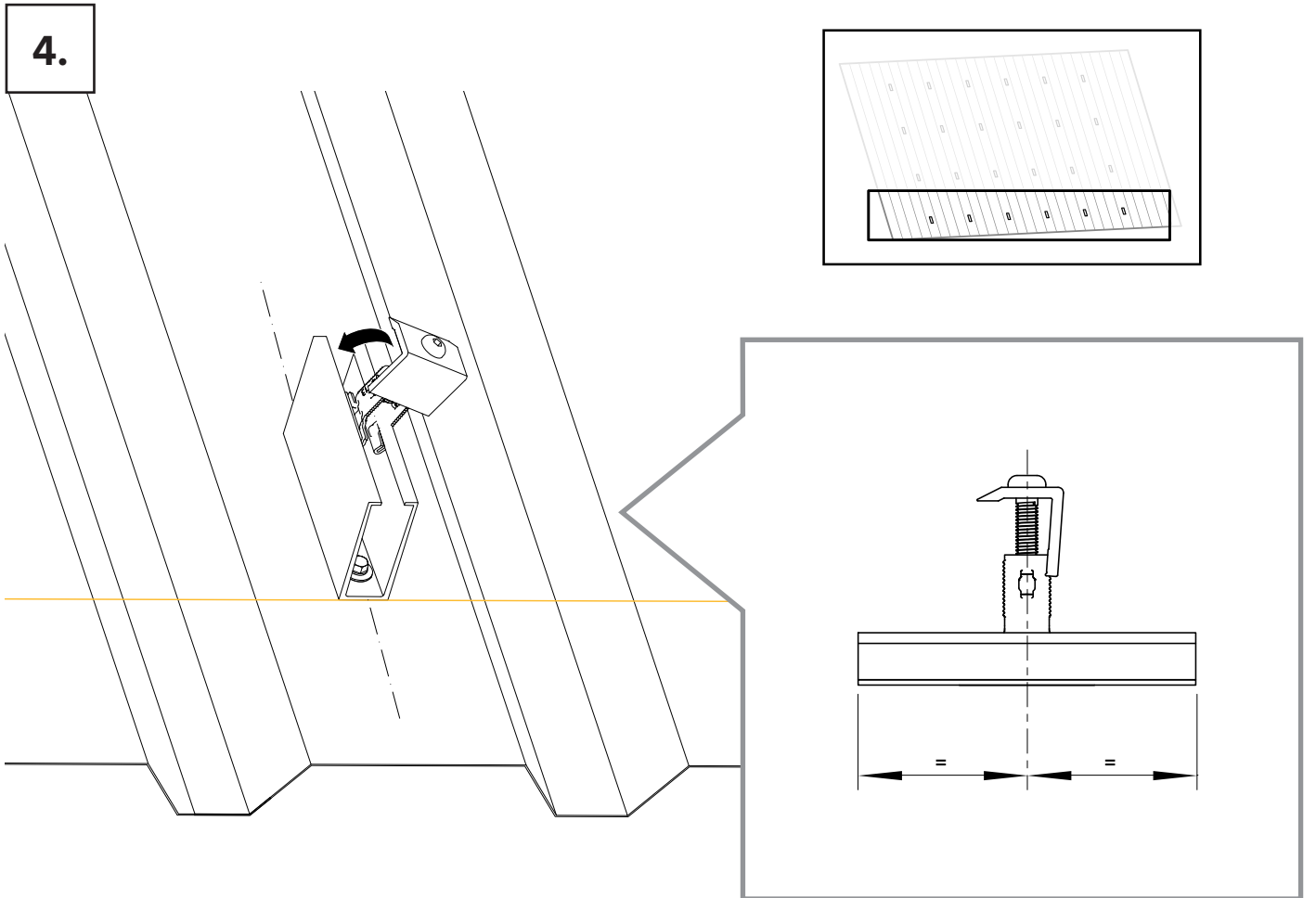
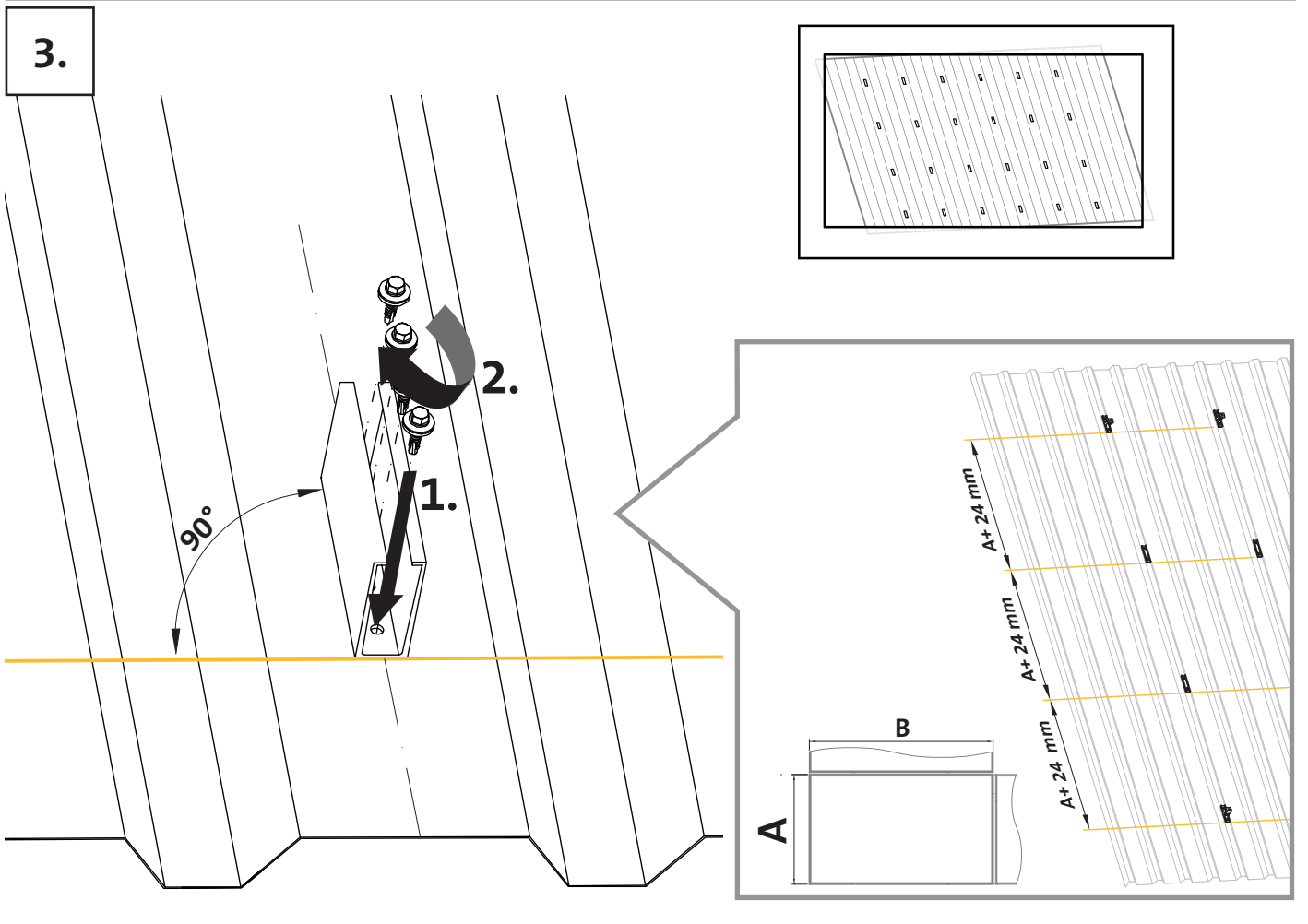

5.

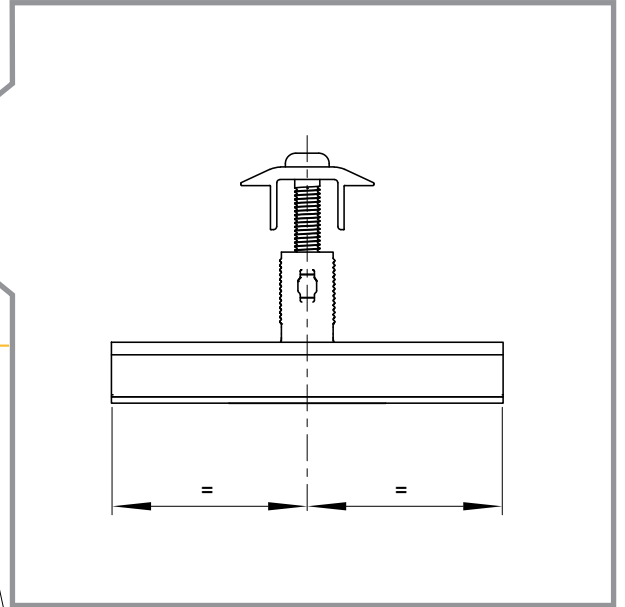
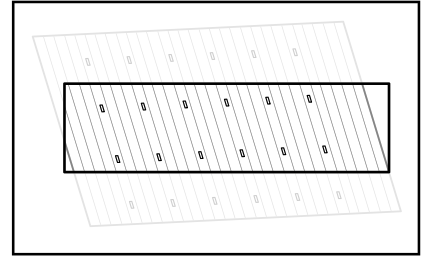
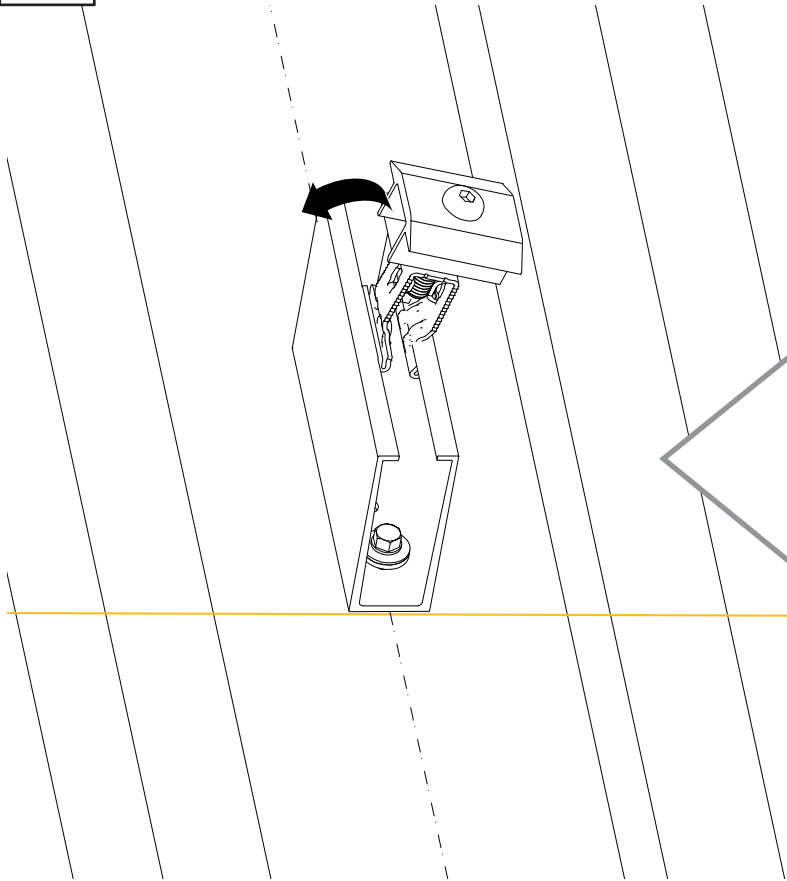

6.

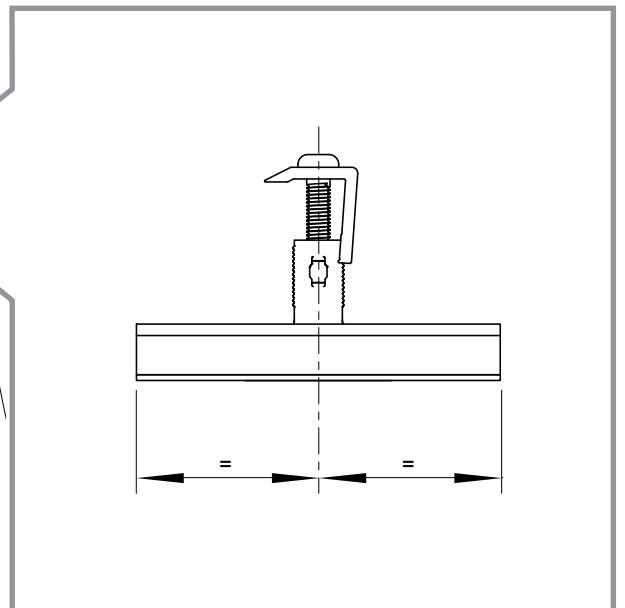
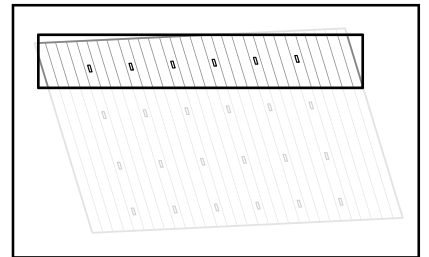
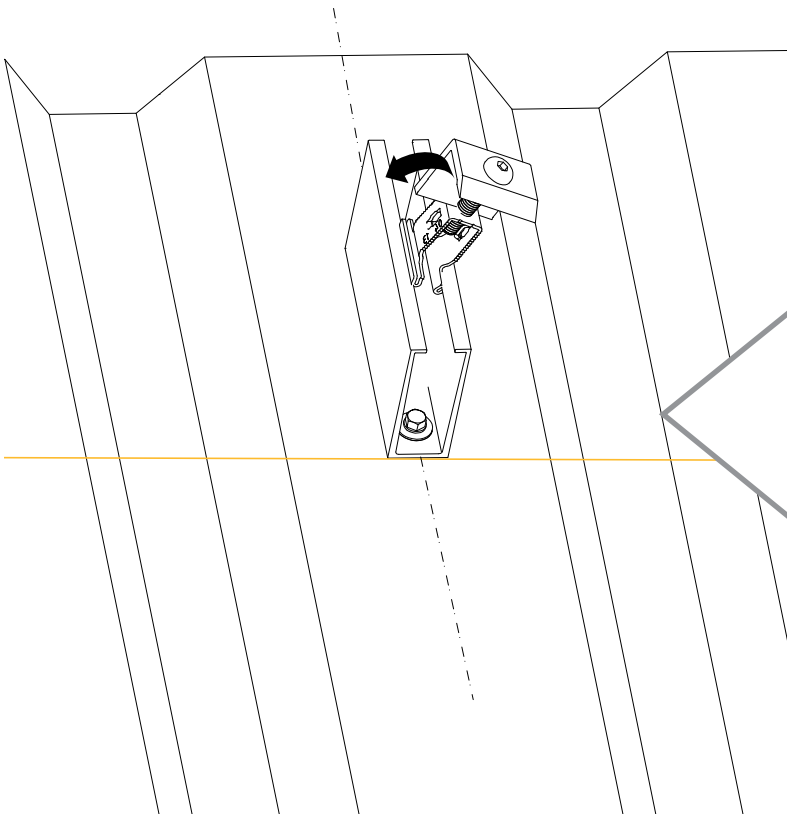

7.

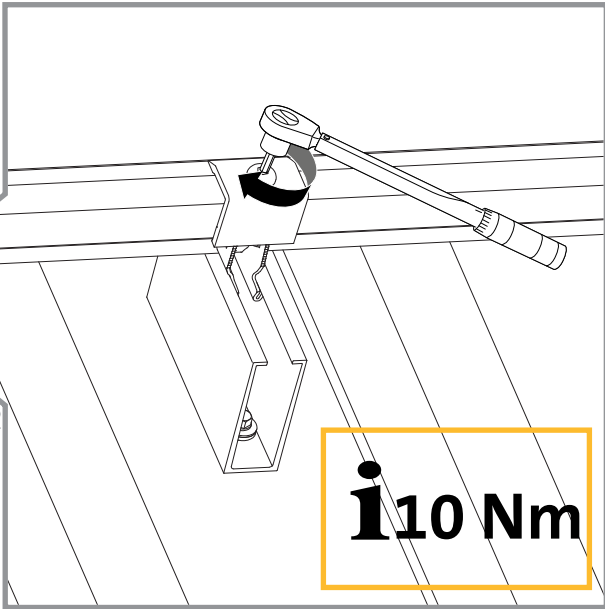
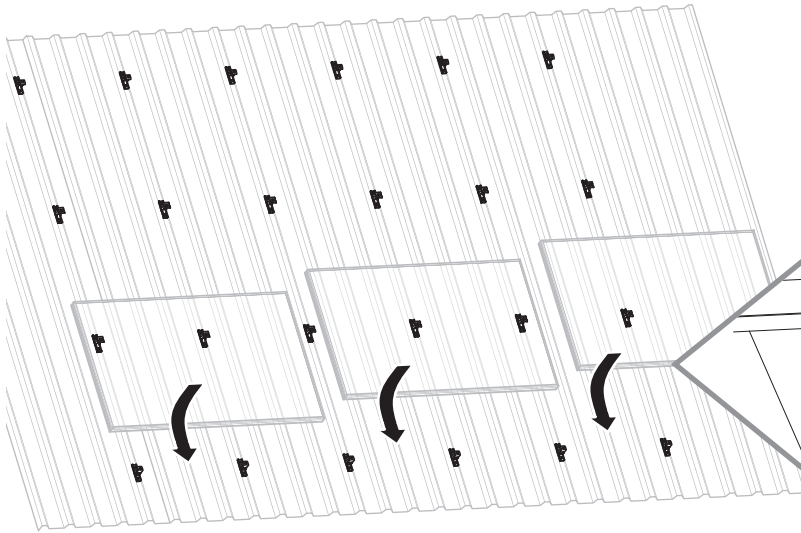
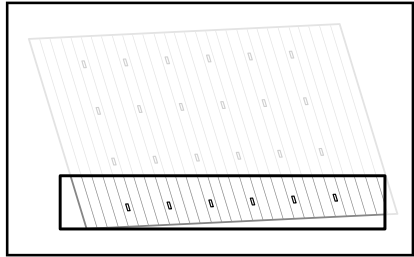

8.

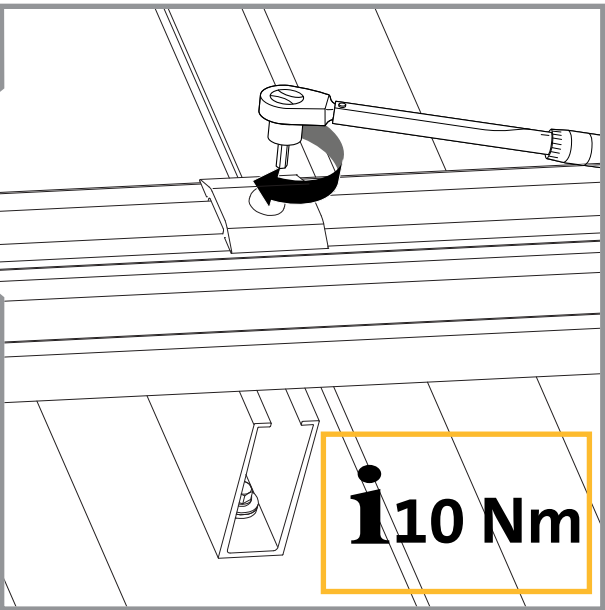
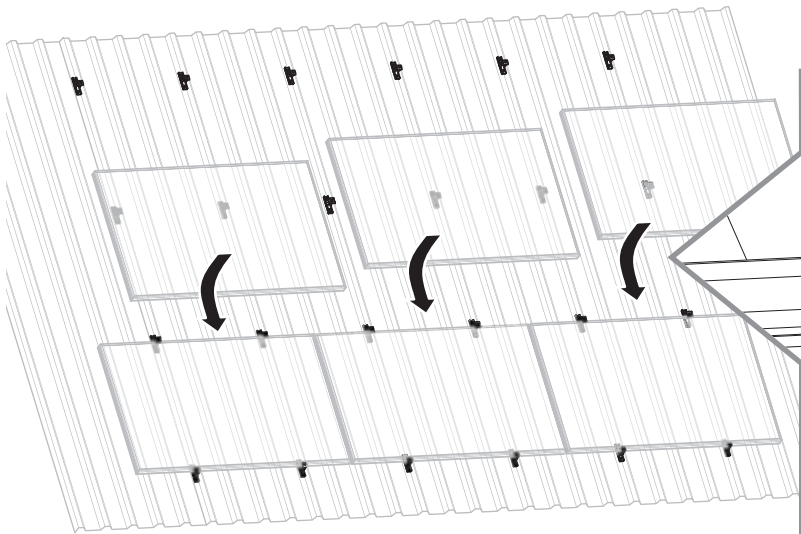
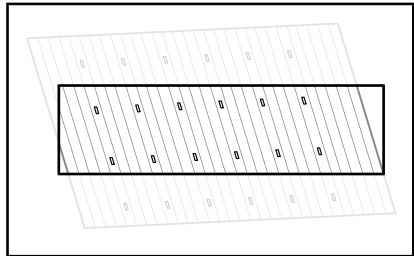

9.

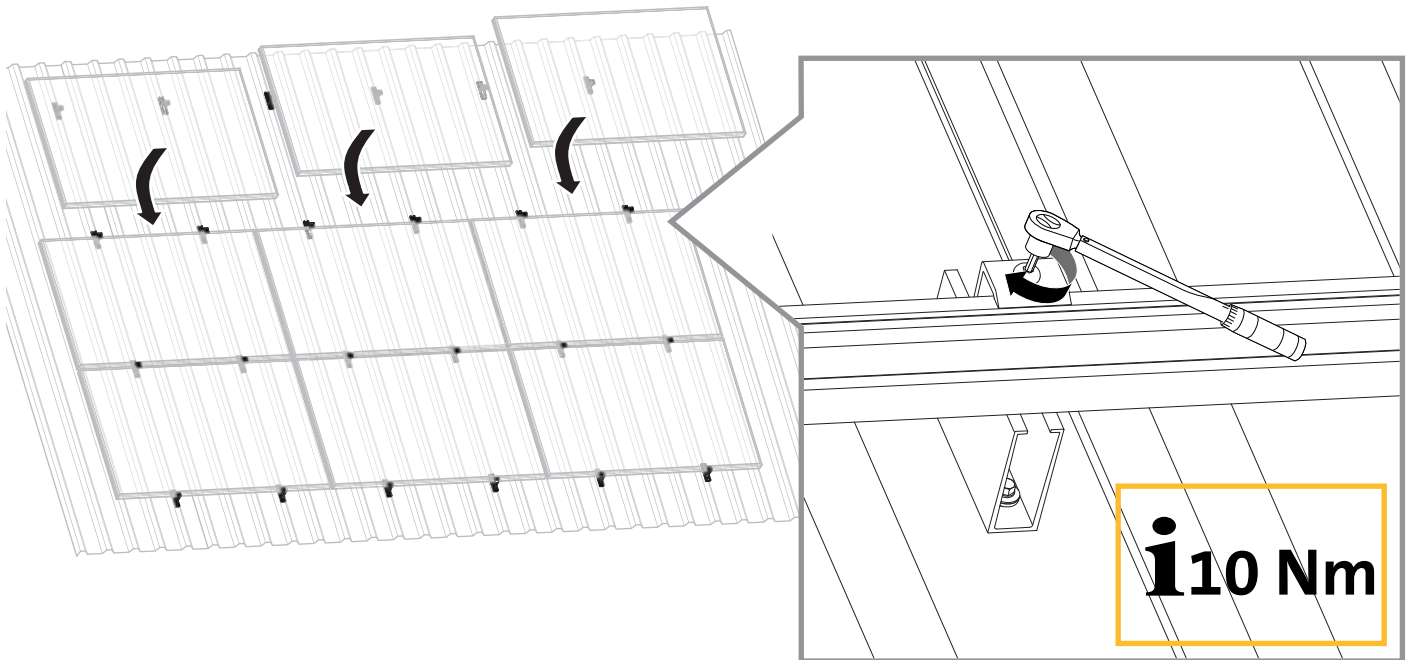
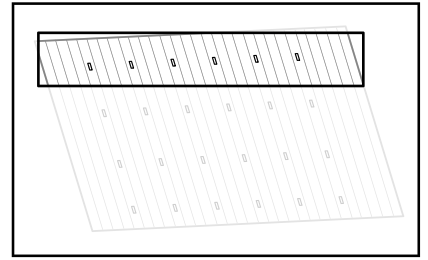

**A.**

Product name	Product Model name	Maximum Design Wind Uplift Resistance (kPa for full system)	Partial (safety) factor(s)
MetaSole+ / MS+ (Sandwich profiles)	REN_MS+_01	0,91	1,25
MetaSole+ / MS+ (Trapezoidal profiles)	REN_MS+_02	1,42	1,00

**Product name certificated**

MetaSole+ / MS+ (Sandwich profiles)

**Product Model name certificated**

REN\_MS+\_01

System component	Part number
End clamp+ (black)	R420081-BE
Middle clamp+ (black)	R420082-BE
End clamp+	R420081
Middle clamp+	R420082
RS1	R420080
RS1 (black)	R420080-BE
RS Pro (black)	R420025-B
RS Pro	R420025
End clamp+ 50mm (black)	R420028-BE
Middle clamp+ 50mm (black)	R420029-BE
End clamp+ 50mm	R420028
Middle clamp+ 50mm	R420029
MetaSole+	R420402
MS+H (Set)	R420423
MS Pro	R420412
Self drilling screw 5,5x25 SW 8 E16	R400301

**Product name certificated**

MetaSole+ / MS+ (Trapezoidal profiles)

**Product Model name certificated**

REN\_MS+\_02

System component	Part number
End clamp+ (black)	R420081-BE
Middle clamp+ (black)	R420082-BE
End clamp+	R420081
Middle clamp+	R420082
RS1	R420080
RS1 (black)	R420080-BE
RS Pro (black)	R420025-B
RS Pro	R420025
End clamp+ 50mm (black)	R420028-BE
Middle clamp+ 50mm (black)	R420029-BE
End clamp+ 50mm	R420028
Middle clamp+ 50mm	R420029
MetaSole+	R420402
MS+H (Set)	R420423
MS Pro	R420412
Self drilling screw 5,5x25 SW 8 E16	R400301

Renusol Europe GmbH  
Piccoloministrasse 2  
51063 Cologne  
Germany  
Telephone: +49 221 788707-0  
Fax: +49 221 788707-99  
Email: info@renusol.com  
www.renusol.com

Sales department  
Telephone: +49 221 788707-19  
Fax: +49 221 788707-97  
Email: sales-support@renusol.com

Application technicians  
Telephone: +49 221 788707-29  
Fax: +49 221 788707-98  
Email: technical-support@renusol.com

- DE | Abbildungen und Texte entsprechen dem aktuellen technischen Stand bei Drucklegung, Änderungen vorbehalten.
- GB | The images and texts in these instructions relate to the latest technology at the time of printing, subject to modifications.
- FR | Les illustrations et textes sont conformes à l'état de la technique au moment de mise sous presse. Sous toutes réserves de modifications.
- IT | Figure e testi corrispondono allo stato più attuale della tecnica al momento dell'ordine di stampa. Con riserva di modifiche.
- ES | Las imágenes y los textos se corresponden al estado actual de la técnica en el momento de la impresión, reservado el derecho a las modificaciones.
- NL | Afbeeldingen en teksten voldoen aan de actuele stand van de techniek op het moment van ter perse gaan. Wijzigingen voorbehouden.
- DK | Afbildninger og tekster overholder den tekniske stand ved trykningen, der tages forbehold for ændringer.
- SE | Bilder och texter motsvarar den nuvarande tekniska tillstånd vid tidpunkten för tryckning, med förbehåll för ändringar.
- CZ | Vyobrazení a texty odpovídají aktuálnímu technickému stavu při odevzdání do tisku. Změny vyhrazeny.
- PL | Ilustracje i teksty odpowiadają stanowi techniki aktualnemu w chwili oddania instrukcji do druku. Zastrzega się prawo do zmian.
- LT | Spausdinami paveikslėliai ir tekstas atitinka naujausią technikos lygį. Pasilieka me teisę į pakeitimus.
- HU | Az ábrák és a szövegek a nyomtatás időpontjában rendelkezésünkre álló legfrissebb műszaki ismereteknek felelnek meg; a módosítások jogát fenntartjuk.