

Renusol **FS** Pro 10-S-IFP

EN | Installation Guide

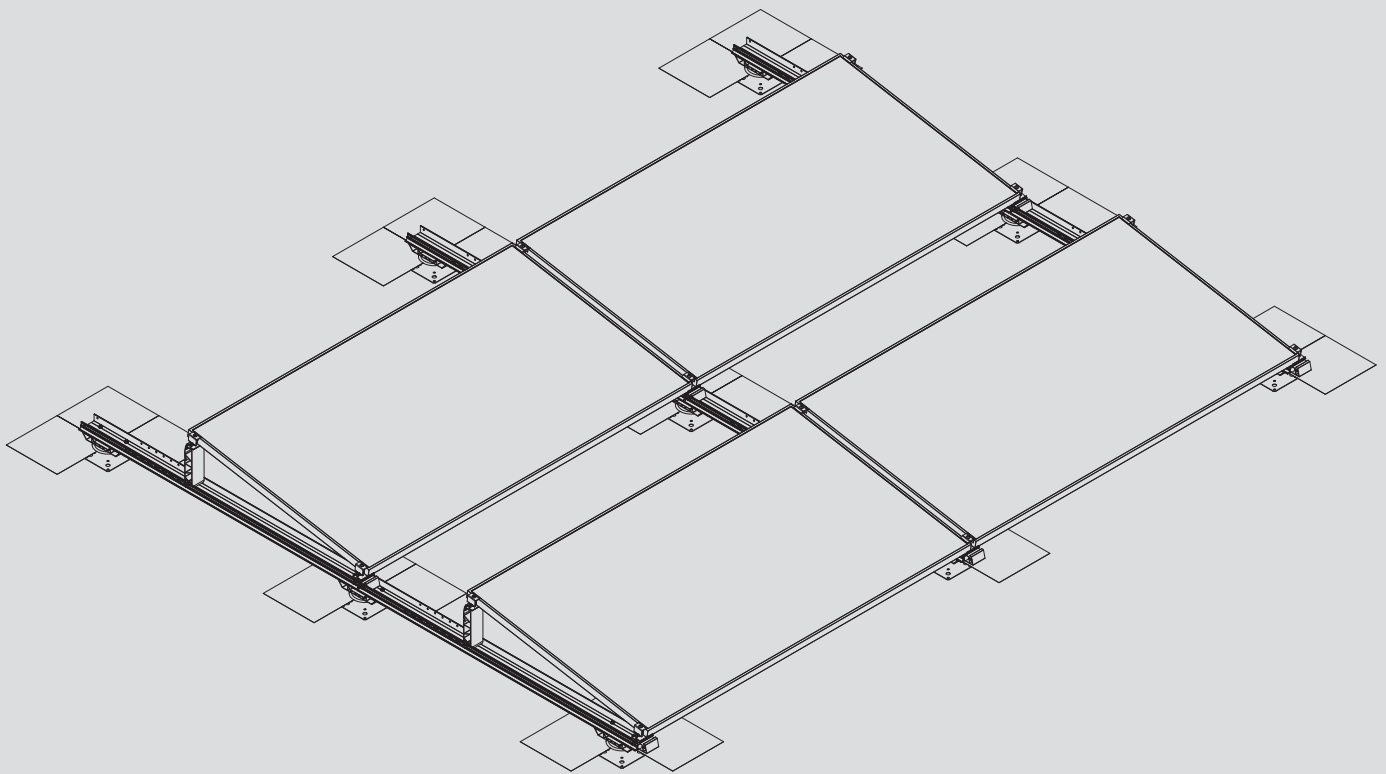

Preface to the Installation with Fixed Elements

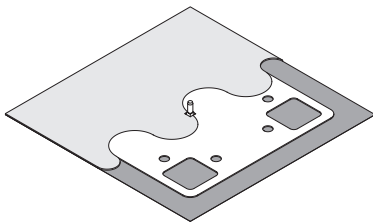
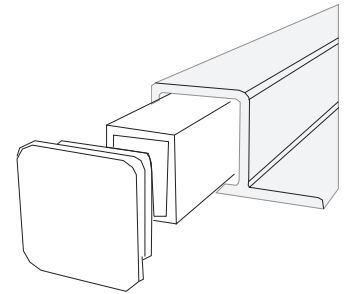
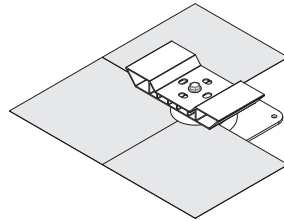
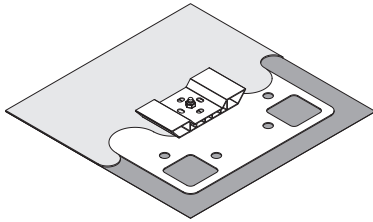

EN | Usage

Mounting system for the installation of framed PV modules on flat roofs with a roof inclination of up to 5°-10° with roof penetration.

Before installation

The Renusol FS Pro is screwed with third-party products (Nicholson Rooftrack, Solmont, Ejot-Ejotbar, etc.) to withstand wind loads. The required fastening depends on the underlying roof structure and must be determined in consultation with the third-party provider. Check with the Renusol PV Configurator whether installation variant A is statically suitable, considering regional conditions. Depending on the third-party product used, the type of connection to the Renusol substructure may differ.

In the Renusol FS Pro 10-S-IFP mounting system, the module is attached at the corner area of the short module side. It must be checked on-site whether the clamping area specified by the module manufacturer is maintained and whether the permissible module loads are not exceeded.

Drainage holes in the PV module frame must be kept clear and must not be covered by the mounting system. The roof surface must be free of snow, ice, and dirt for installation. Observe the applicable regulations, state-of-the-art technology, and current occupational safety guidelines during installation.

A suitable substructure that can absorb the occurring forces (weight load, wind, and snow load) is always a prerequisite for proper use. The roof covering must be suitable for screwing and subsequent bonding or welding.

EN | Wind Report

The suction and pressure coefficients have been determined in wind tunnel tests.

Applicable Documents

"General Installation, Maintenance, and Assembly Instructions,"
"Warranty Conditions and Disclaimer."

These documents are available at www.renusol.com.

Warranty and Guarantee

Renusol's warranty applies only when using the original Renusol FS Pro complete system in compliance with the warranty conditions. For statutory defect liability/warranty, please refer to Renusol's General Terms and Conditions.

Tests/certificates

The system was tested in the setup of a specific 2x1 module configuration according to MCS 012 Issue 3.0 standard at a PV module surface of 5,4 m². Permissible wind uplift values for this configuration and other relevant clauses can be found in Annex MCS 012 certification on page 14.

www.renusol.com

Renusol FS Pro 10-S-IFP Bill of Materials

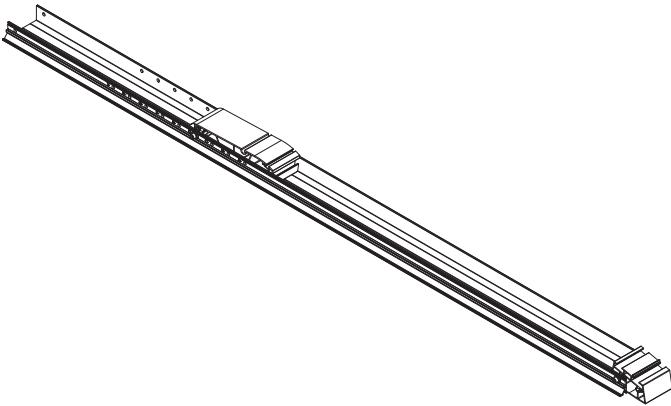
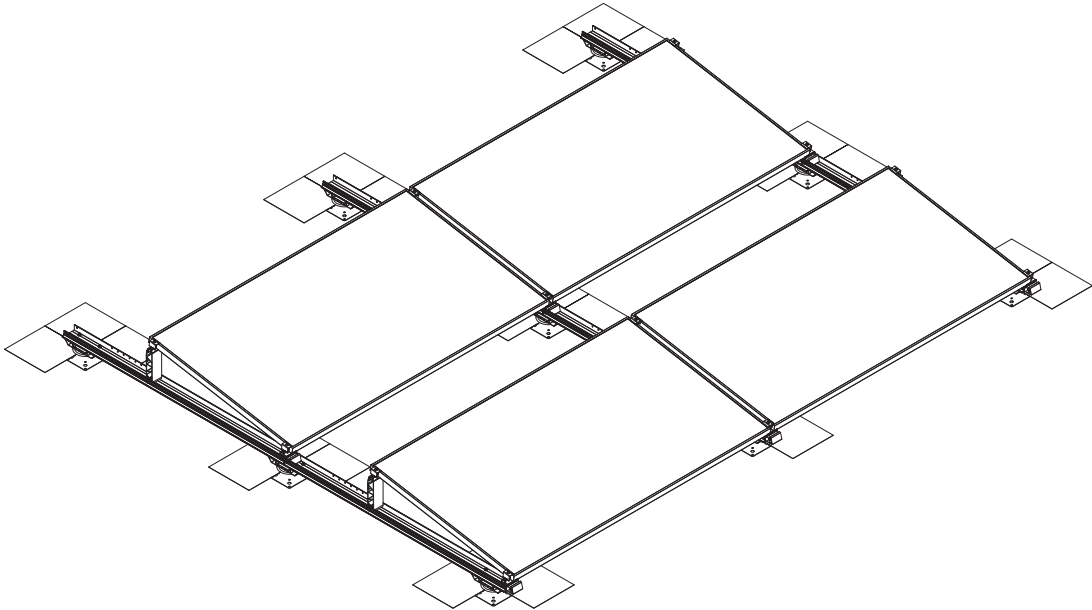

*R52024
FS Pro 10-S Base rail 1500 (Set) IFP*

*R500264
FS Pro IFP Mounting Bracket*

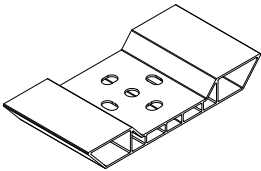

*R900268 (optional)
P-Clip Potential equalization*

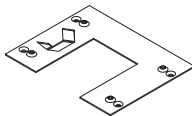

*R420081 / R420081-B
End clamp+
End clamp+ (black)*

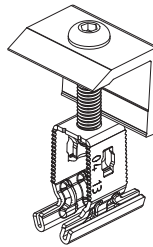

*R420082 / R420082-B
Middle clamp+
Middle clamp+ (black)*

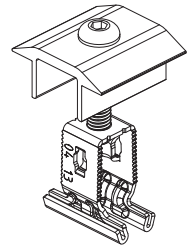

*R400301
Self drilling screw 5,5 x 25 SW8
E16*

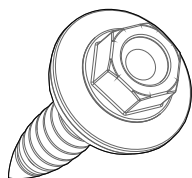

*R500260
FS Pro Potential equalisation
clip S*

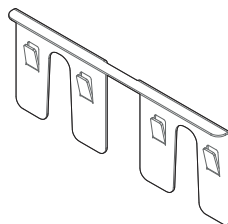

*R500227
FS Pro Securing bolt
clip S*

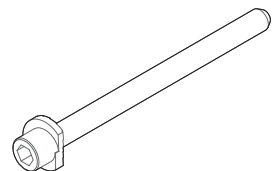

Preface

EN | Usage

The ridge support is pre-assembled for modules with a width between 1110-1150 mm.

If your module dimensions differ, please reposition the ridge support as shown in Step 1 a-d.

The support must be repositioned in a horizontal position.

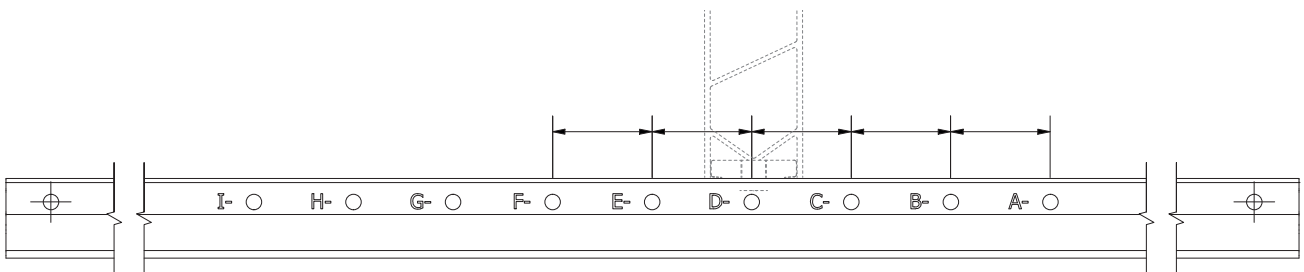
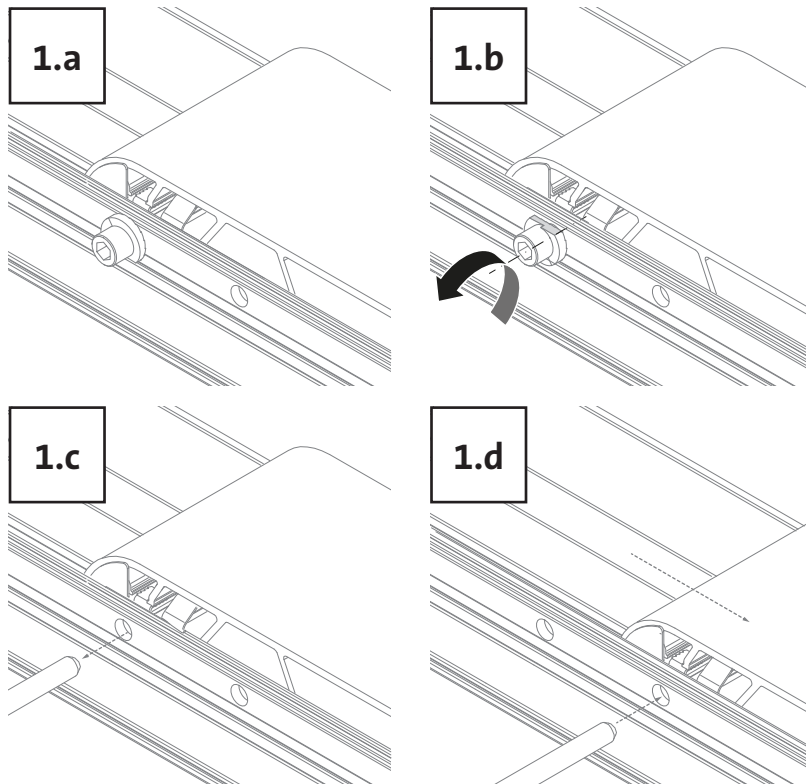
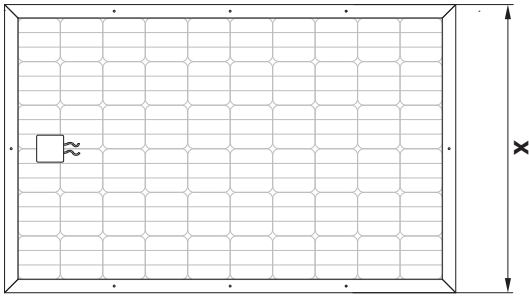

Module Width	Ridge Support
990-1030 mm	A
1030-1070 mm	B
1070-1110 mm	C
1110-1150 mm	D
1150-1190 mm	E
1190-1230 mm	F

1.B

Installation Variant A

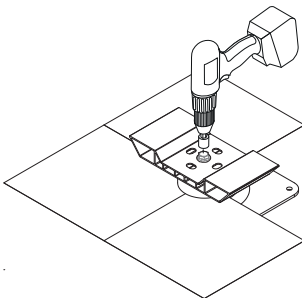
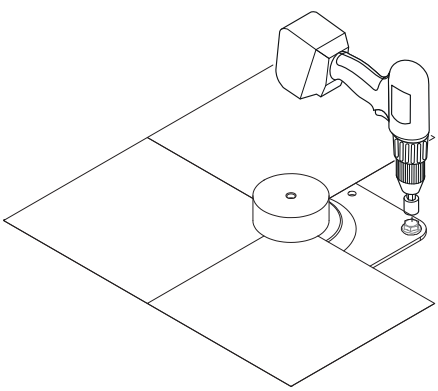
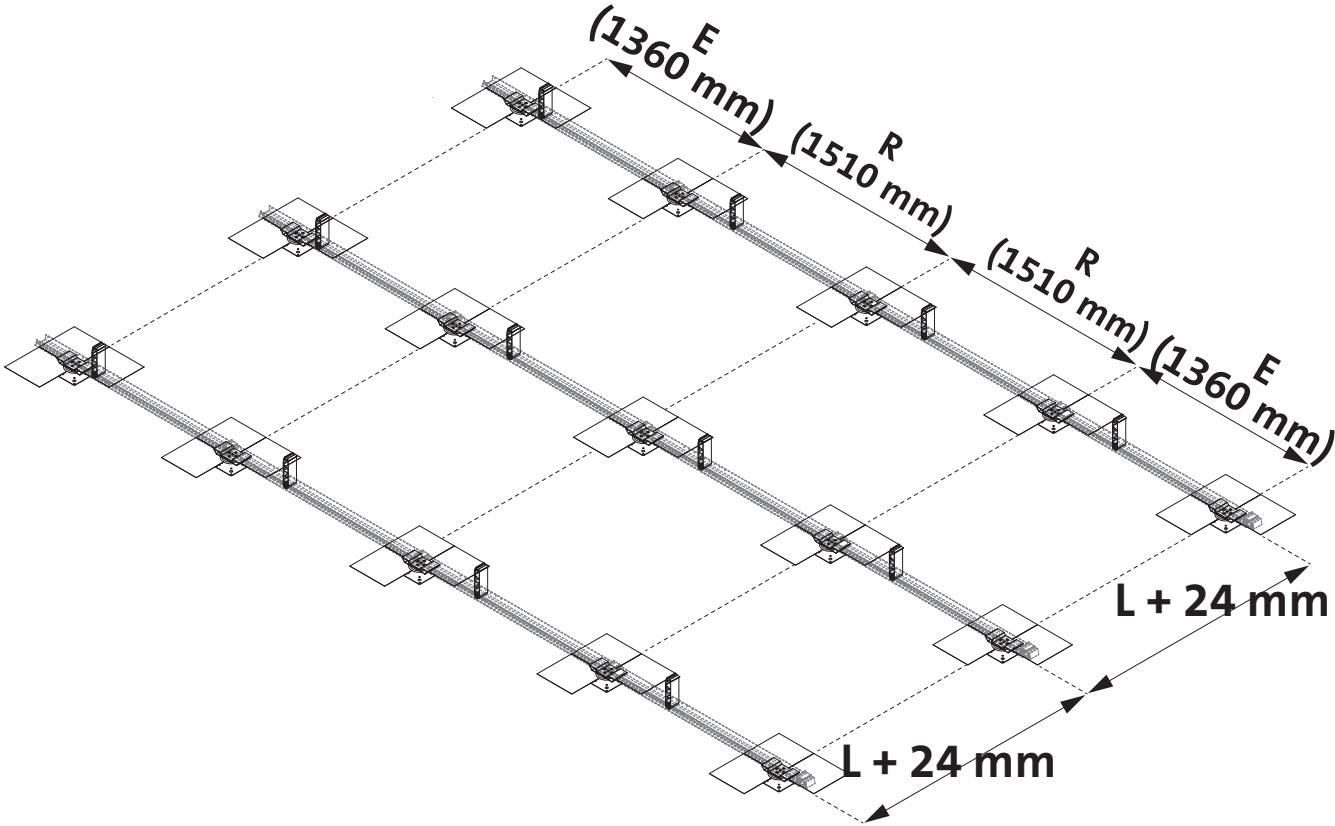

The distance (R) is continuously repeated except for the recessed IFPs at the end (E).

For the installation of the third-party product, the instructions in the respective manufacturer's manual must be followed and complied with. Pay particular attention to the installation instructions and recommendations regarding waterproofing and foil compatibility, which are also the responsibility of the third-party provider.

1.B

Installation Variant B

Module:	Dim: X
990-1030	≈924 mm
1030-1070	≈964 mm
1070-1110	≈1.004 mm
1110-1150	≈1.044 mm
1150-1190	≈1.084 mm
1190-1230	≈1.124 mm

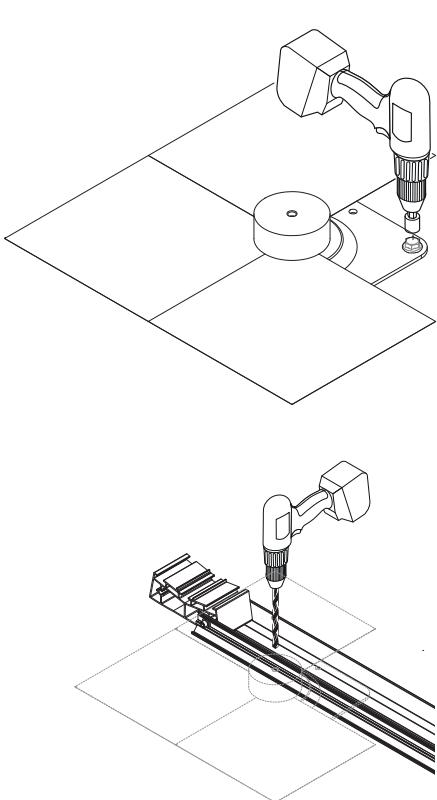
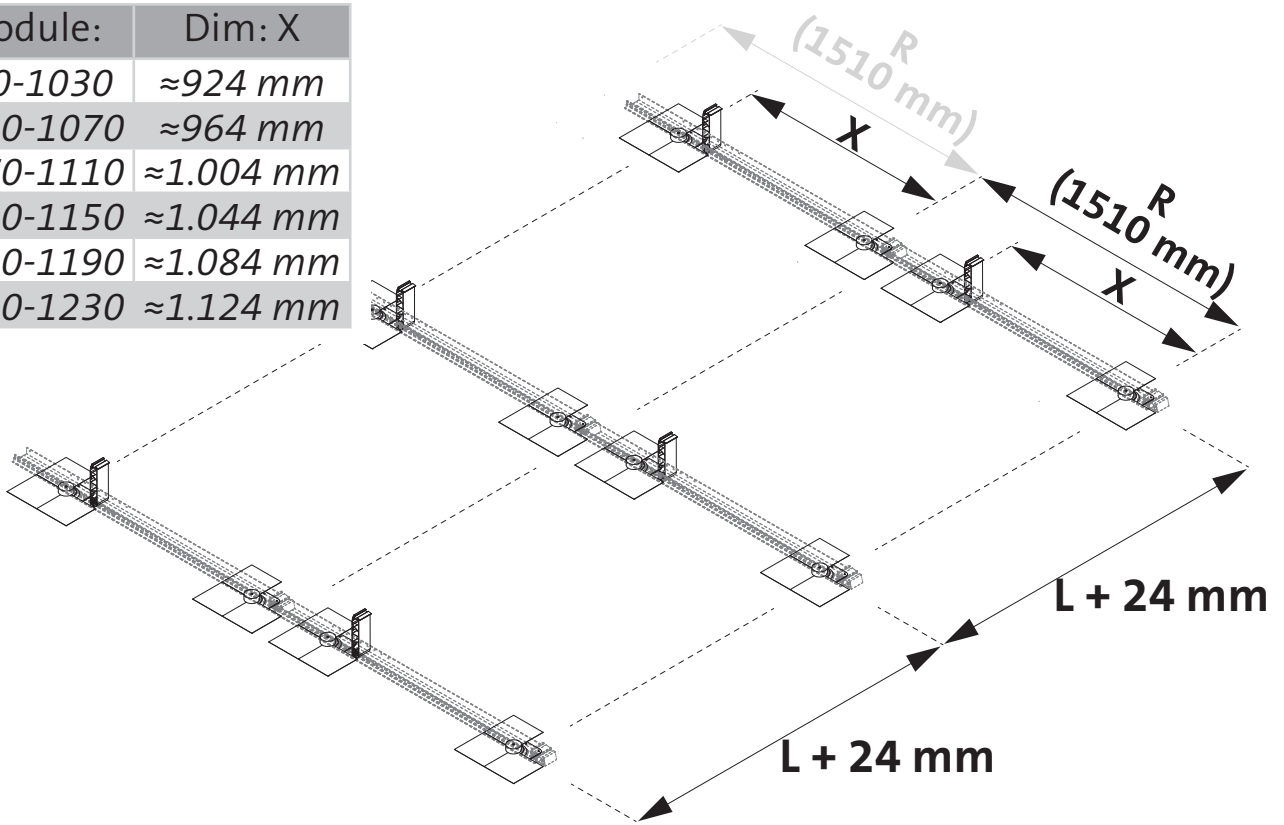

The row spacing (R) is continuously repeated. The dimension X depends on the module width and the associated position of the ridge support.

For the installation of the third-party product, the instructions in the respective manufacturer's manual must be followed and complied with. Pay particular attention to the installation instructions and recommendations regarding waterproofing and foil compatibility, which are also the responsibility of the third-party provider.

Fastening is done using a metric screw directly on the rail. Pre-drill in the center groove with a 10.4–11 mm drill bit. Ensure that the M10 screw is tightened to 51 Nm.

2.1

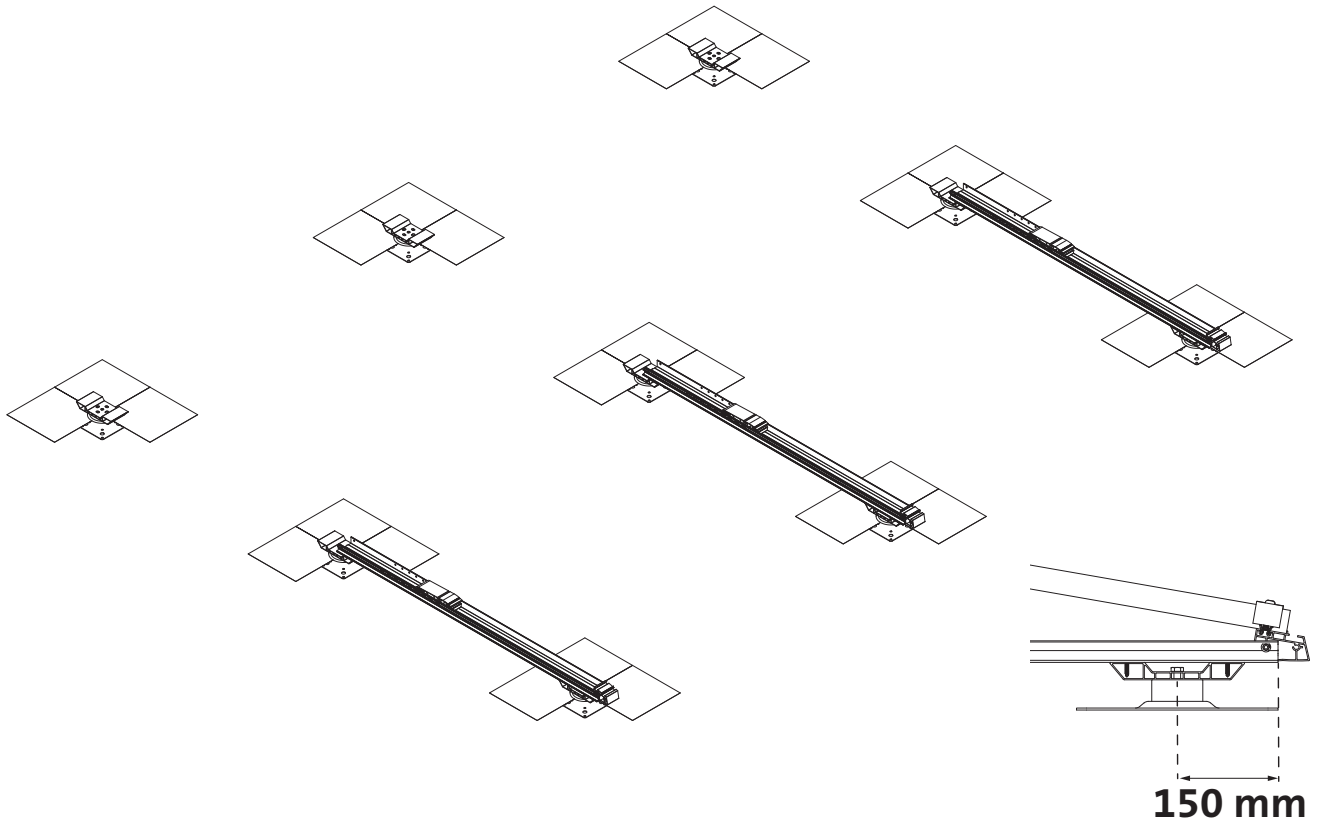

2.2

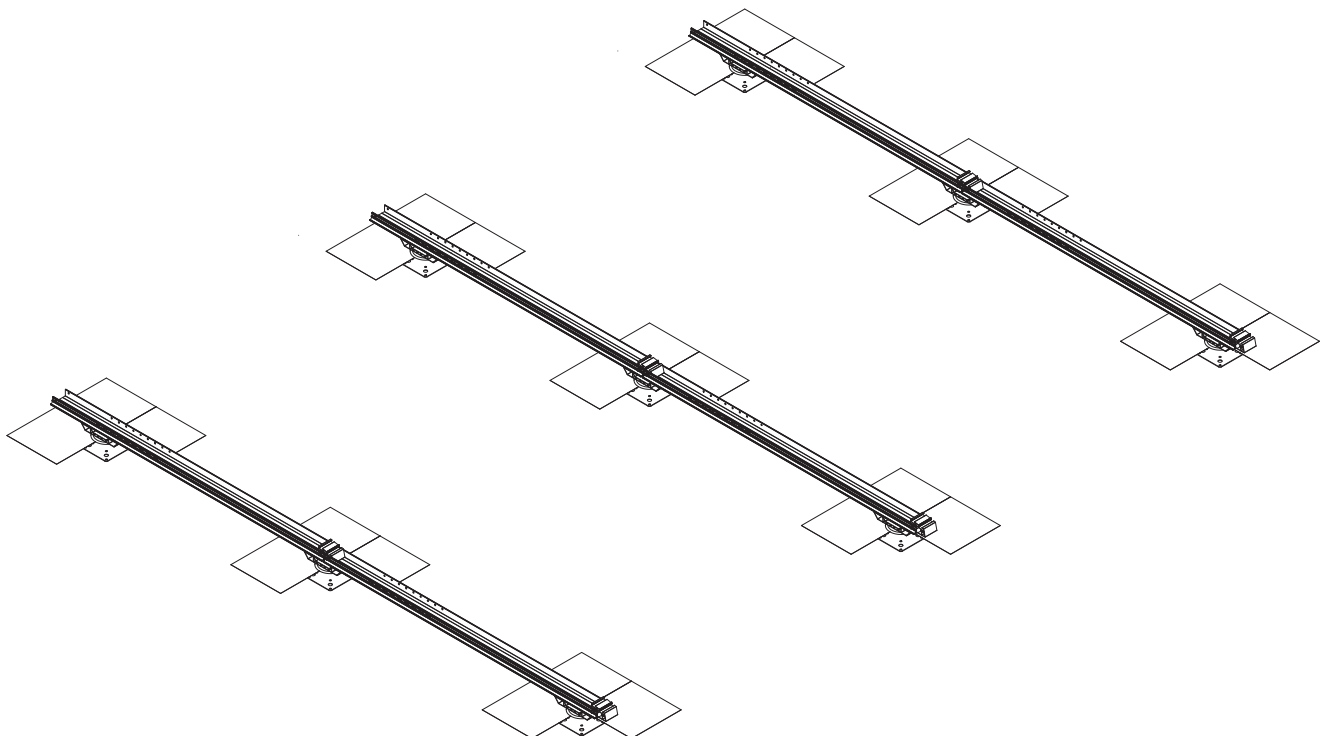

2.

Rail Connection

a.

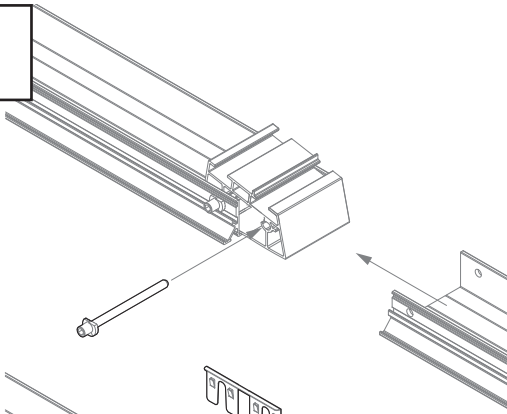

b.

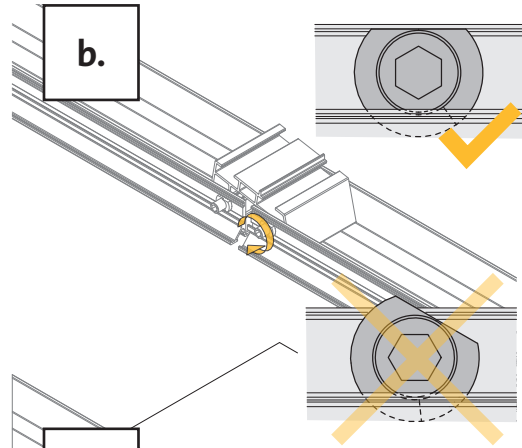

c.

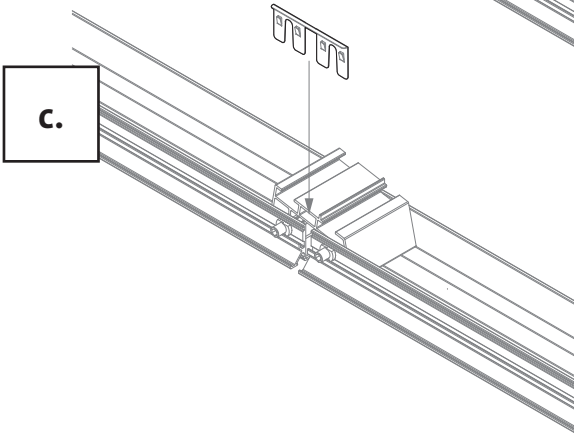

d.

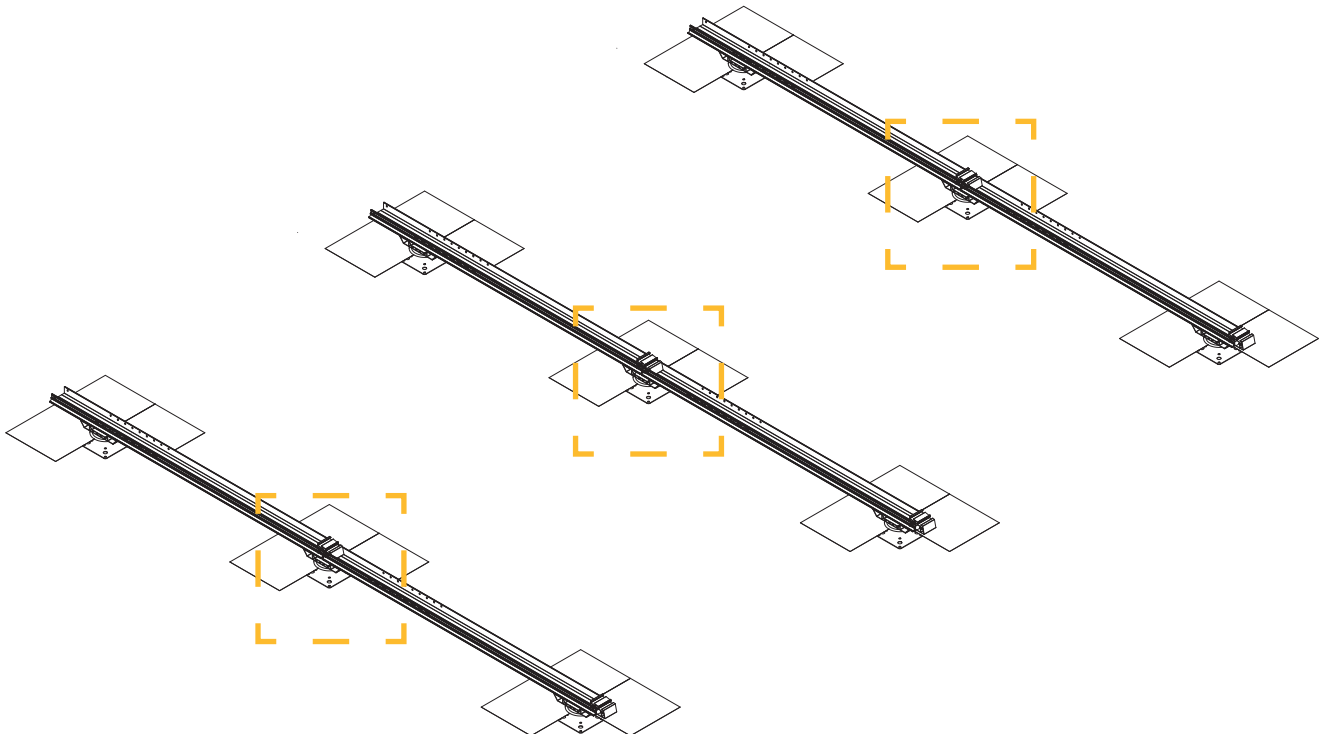
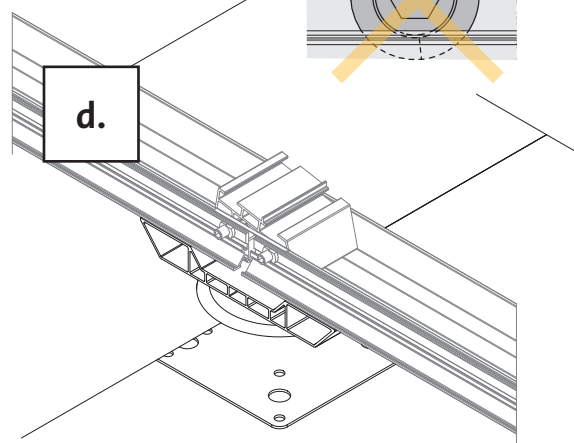

3.

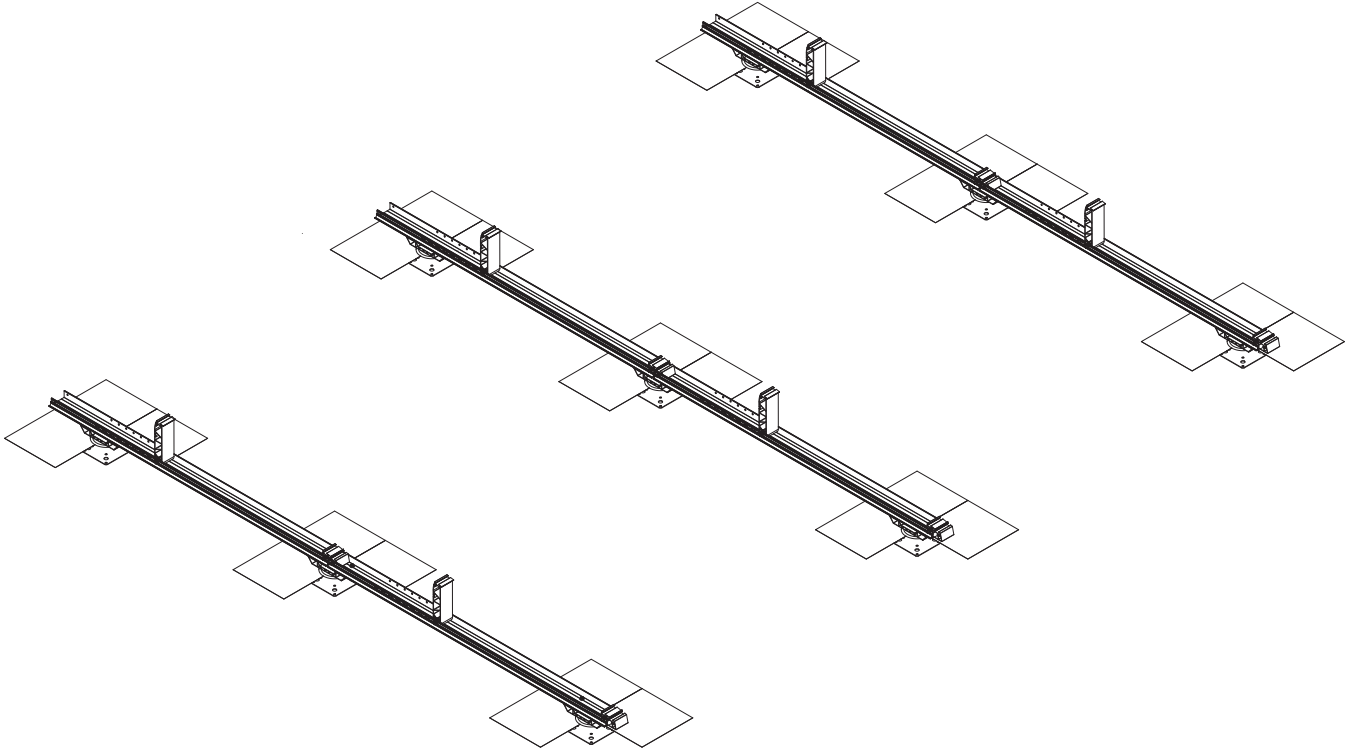
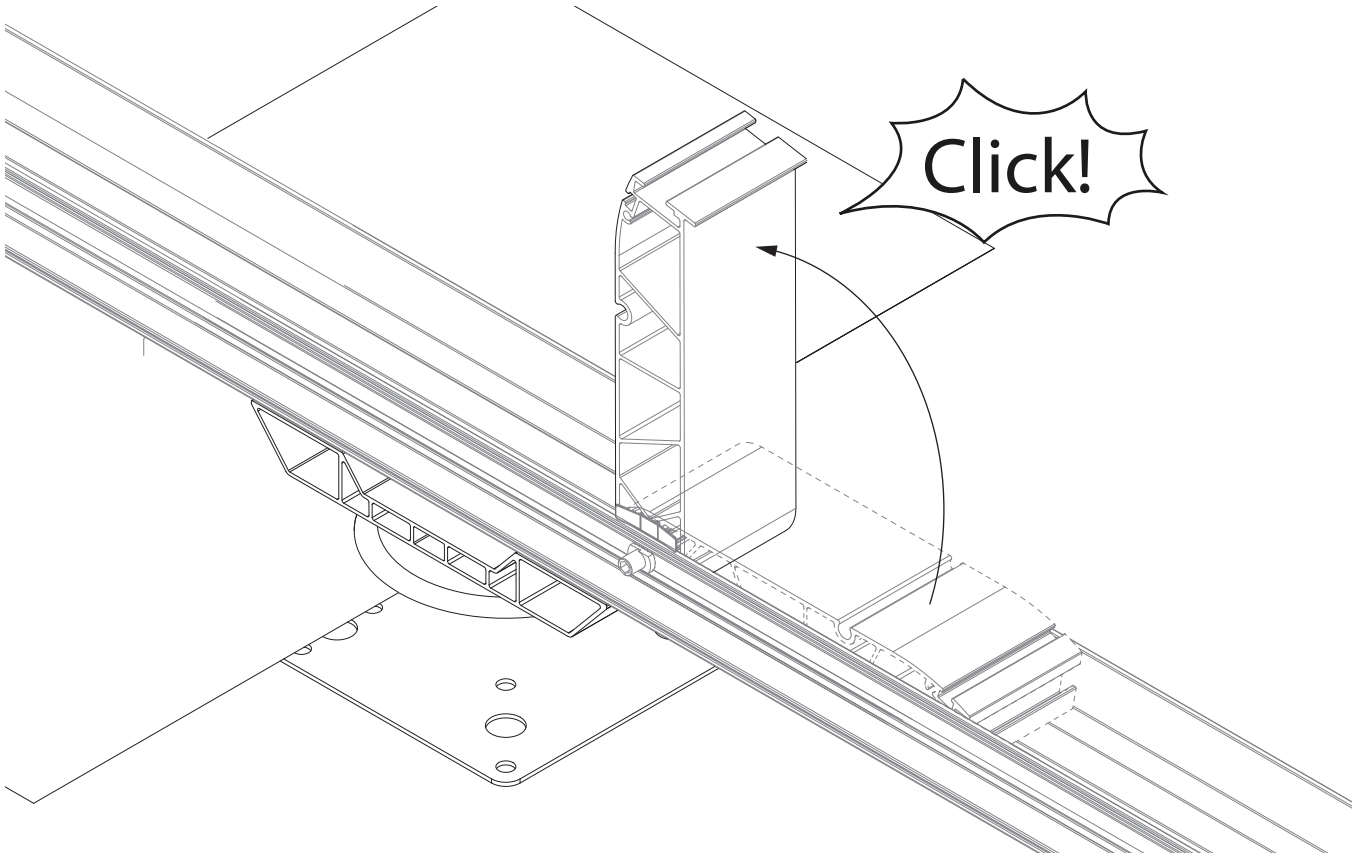

4.A

Installation Variant A

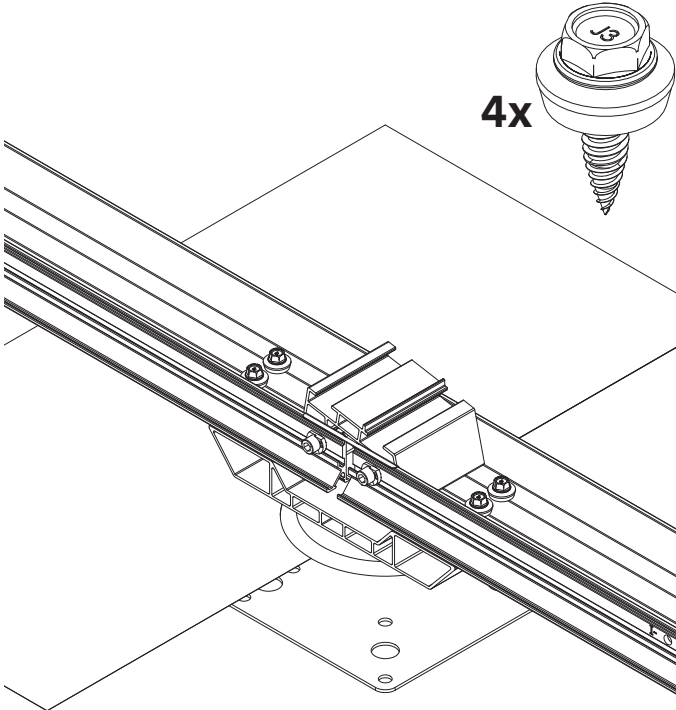
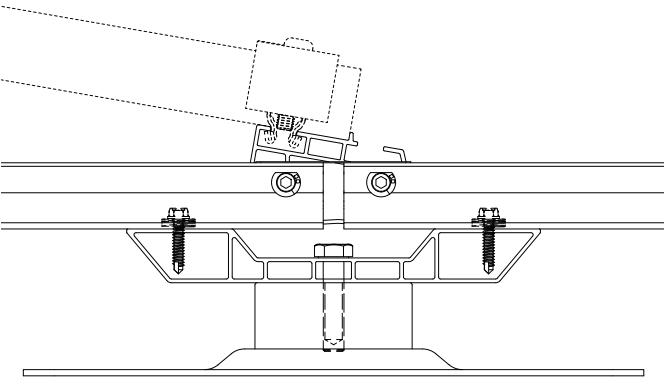
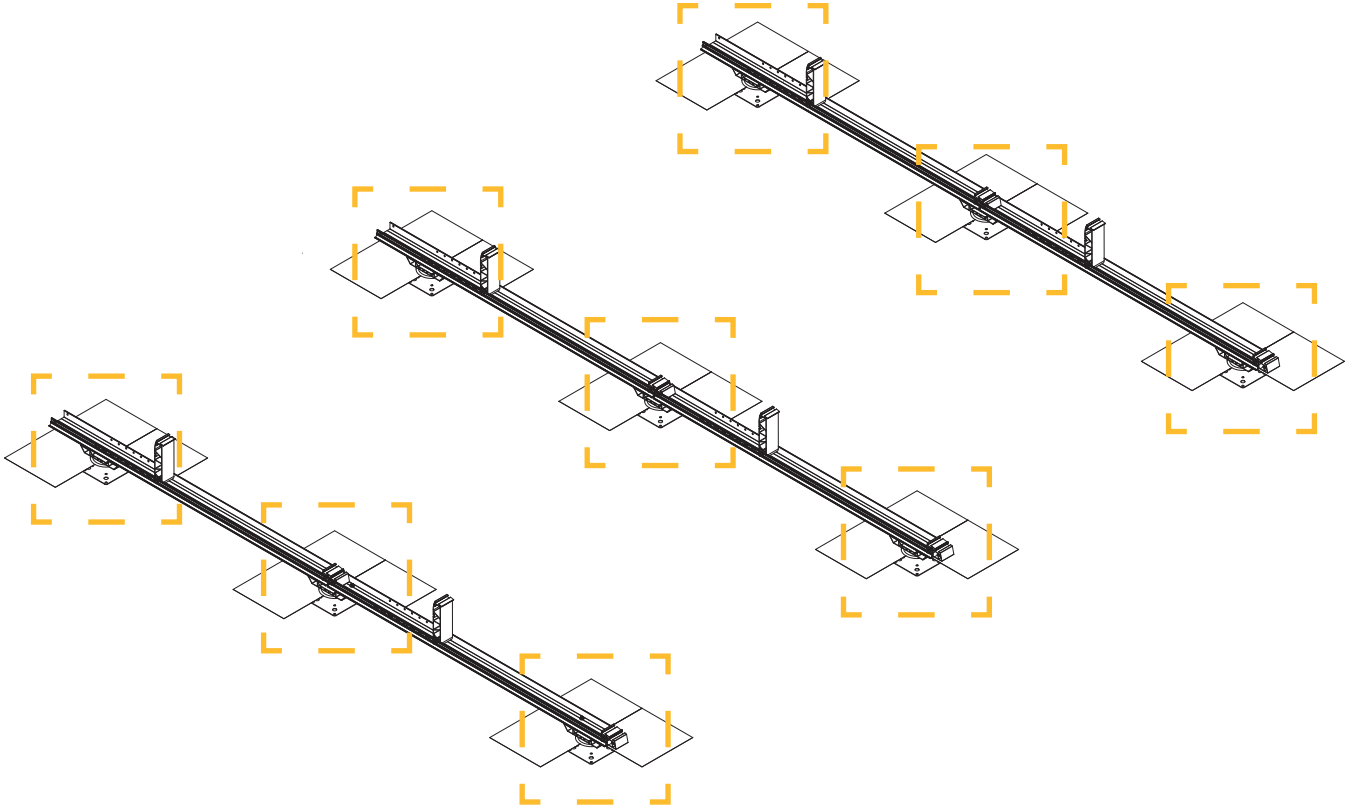

4.B

Installation Variant B

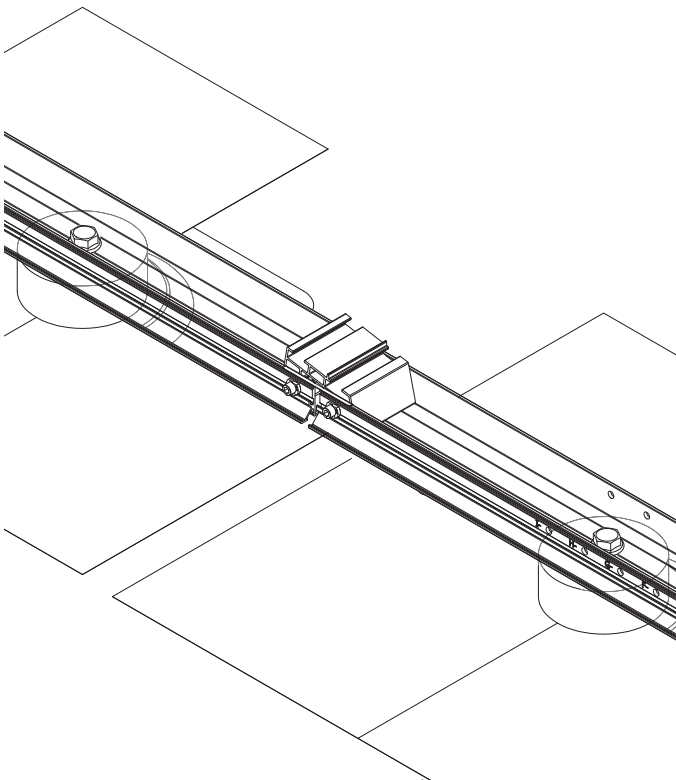
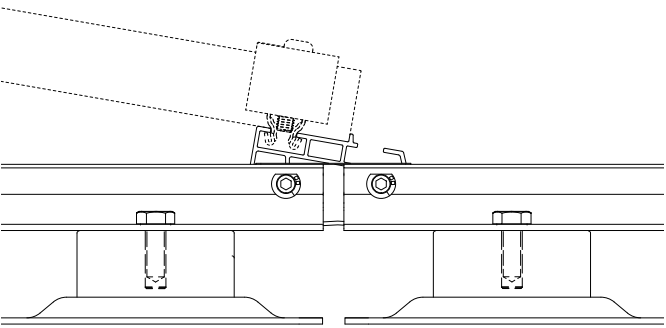
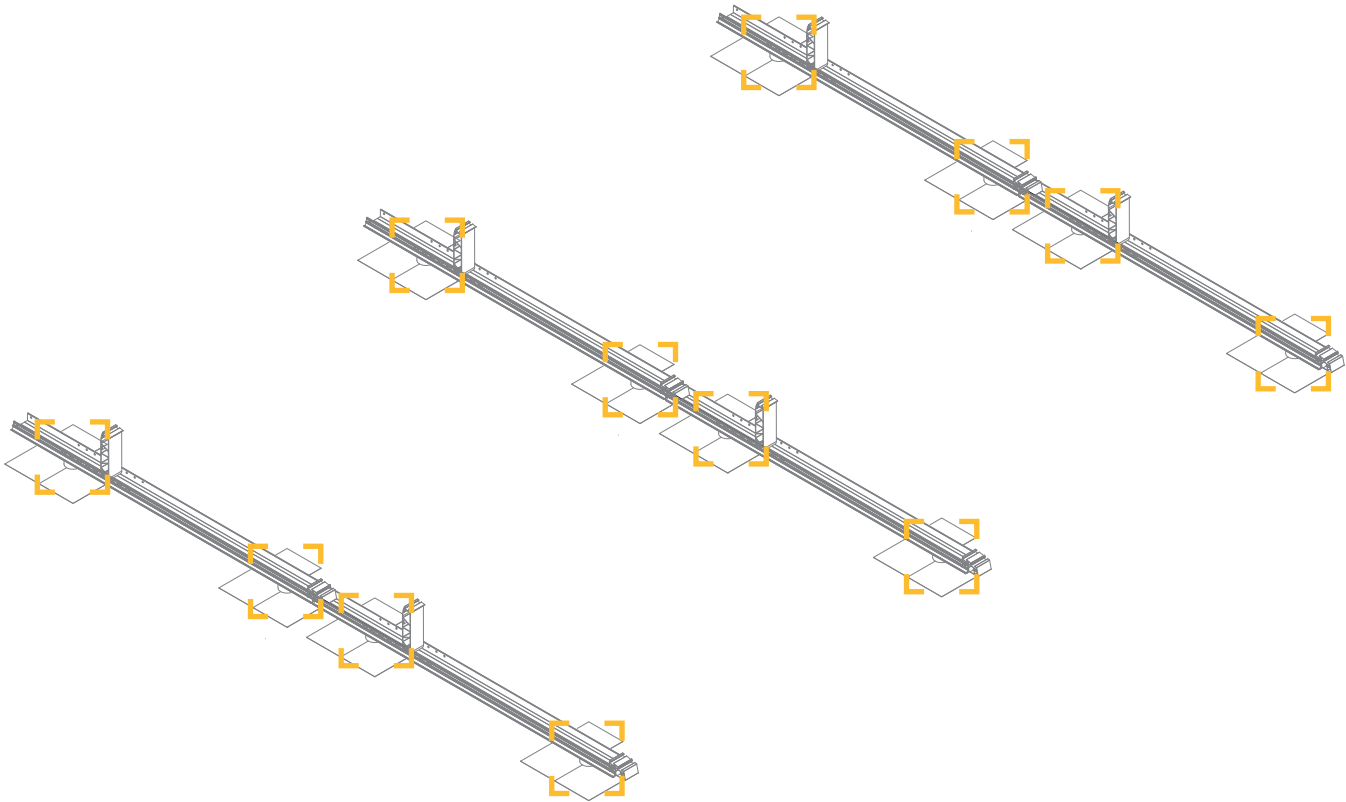

5.

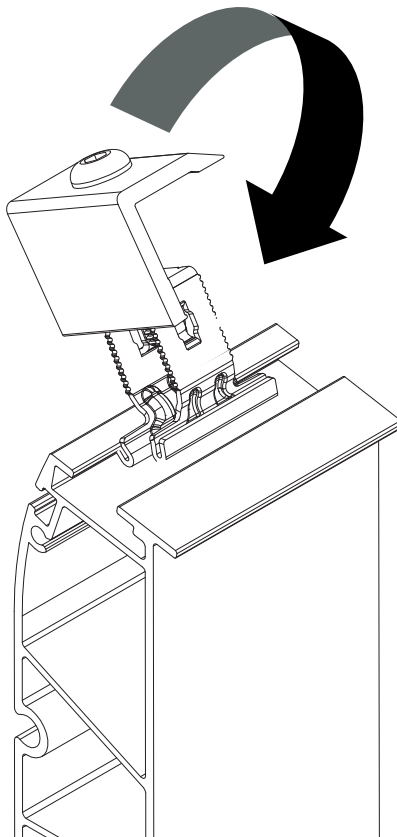
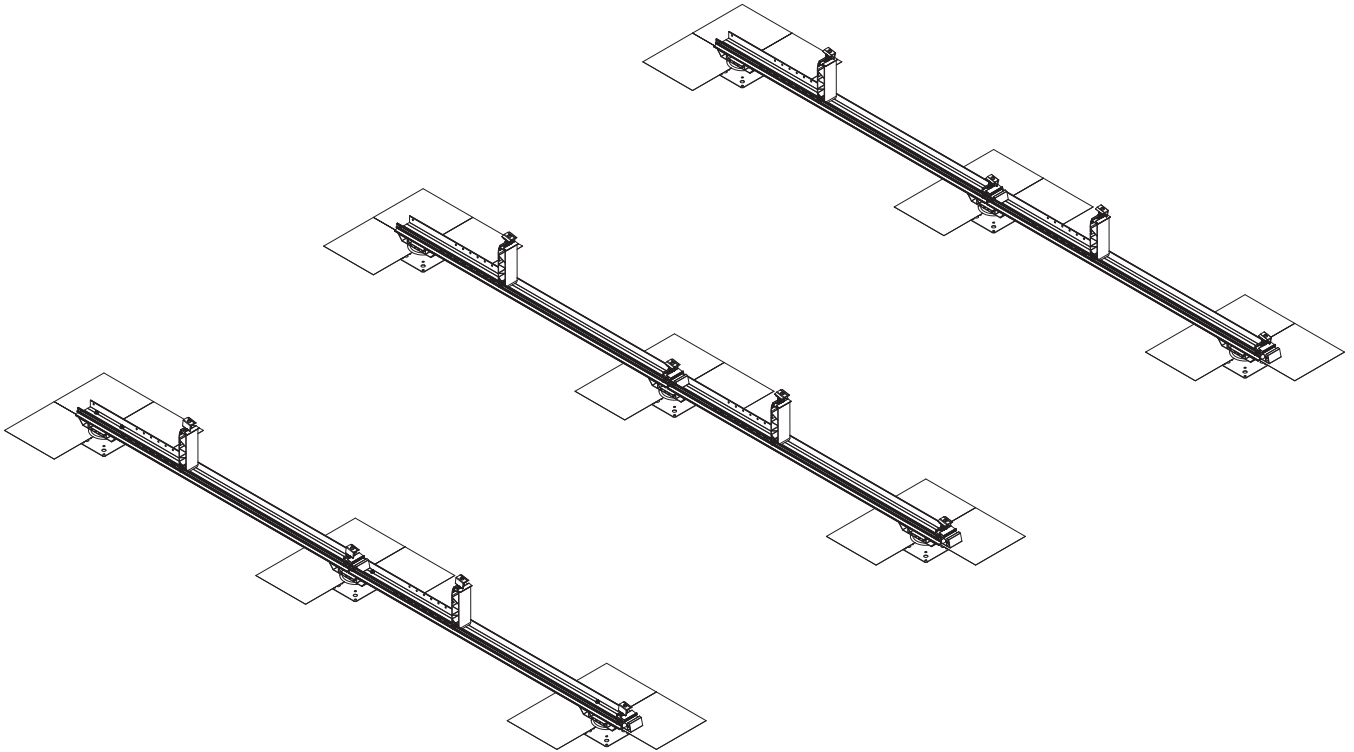

FS Pro 10-S-IFP			
Product name	Product Model name	Maximum Design Wind Uplift Resistance (kPa for full system)	Partial (safety) factor(s)
FS Pro 10-S-IFP		0.96	1.00

Product name certificated	
FS Pro 10-S-IFP	
Product Model name certificated	
REN_FSPRO_03	
System component	Part number
End clamp+ (black)	R420081-BE
Middle clamp+ (black)	R420082-BE
End clamp+	R420081
Middle clamp+	R420082
RS1	R420080
RS1 (black)	R420080-BE
RS Pro (black)	R420025-B
RS Pro	R420025
End clamp+ 50mm (black)	R420028-BE
Middle clamp+ 50mm (black)	R420029-BE
End clamp+ 50mm	R420028
Middle clamp+ 50mm	R420029
FS Pro End clamp LS	R520283
FS Pro 10-S Base rail 1500 (Set) IFP	R520240
FS Pro Ridge support	R500230
FS Pro Securing clip ridge support	R500228
FS Pro Eave support 10-S	R500231
FS Pro Securing bolt	R500227
FS Pro adapter LS	R500235
FS Pro Potential equalisation clip S	R500260
FS Pro Cable tray 450	R500262
FS Pro Side deflector 10 (Set)	R520265
FS Pro IFP Mounting bracket	R500264
Self drilling screw 5,5x25 SW 8 E16	R400301
Rooftrak IFP250 with Single Ply Membran	R999952
Rooftrak IFP250 with Bituminous Membran	R999953

www.pv-configurator.com

- DE | Abbildungen und Texte entsprechen dem aktuellen technischen Stand bei Drucklegung, Änderungen vorbehalten.
- GB | The images and texts in these instructions relate to the latest technology at the time of printing, subject to modifications.
- FR | Les illustrations et textes sont conformes à l'état de la technique au moment de mise sous presse. Sous toutes réserves de modifications.
- IT | Figure e testi corrispondono allo stato più attuale della tecnica al momento dell'ordine di stampa. Con riserva di modifiche.
- ES | Las imágenes y los textos se corresponden al estado actual de la técnica en el momento de la impresión, reservado el derecho a las modificaciones.
- NL | Afbeeldingen en teksten voldoen aan de actuele stand van de techniek op het moment van ter perse gaan. Wijzigingen voorbehouden.
- DK | Afbildninger og tekster overholder den tekniske stand ved trykningen, der tages forbehold for ændringer.
- SE | Bilder och texter motsvarar den nuvarande tekniska tillstånd vid tidpunkten för tryckning, med förbehåll för ändringar.
- CZ | Vyobrazení a texty odpovídají aktuálnímu technickému stavu při odevzdání do tisku. Změny vyhrazeny.
- PL | Ilustracje i teksty odpowiadają stanowi techniki aktualnemu w chwili oddania instrukcji do druku. Zastrzega się prawo do zmian.
- LT | Spausdinami paveikslėliai ir tekstas atitinka naujausią technikos lygį. Pasilieka me teisę į pakeitimus.
- HU | Az ábrák és a szövegek a nyomtatás időpontjában rendelkezésünkre álló legfrissebb műszaki ismereteknek felelnek meg; a módosítások jogát fenntartjuk.

Renusol Europe GmbH

Piccoloministr. 2

51063 Köln

Deutschland

Telefon: +49 221 788707-0

E-Mail: info@renusol.com

www.renusol.com